

Digital Feeder Protection Multi Function Relay Manual

TYPE : K-PAM F300

2017. 03 23

Version 1.16



Kyongbo Electric Co., Ltd.

Safety Precautions

This document is for the safety of the user, and to prevent property damage. Be sure to read the user manual carefully, and use the product accordingly. The user manual must be kept in a place where it can be easily seen by the product user.



WARNING

This symbol indicates the possibility of death or serious injury.



CAUTION

This symbol indicates the possibility of injury or damage to properties only.

SYMBOLS



Be sure not to do.



Be sure to follow the instruction.



WARNING



- **Do not perform any wiring work while the power is on or the product is in operation.**

It may cause an electric shock.



- **Must verify the status of the grounding connection before starting the operation.**

Otherwise, it may cause an electric shock, damage, or a fire.



- **Do not operate the product with wet hands.**

It may cause an electric shock.



- **Do not use if the clothing of the cable is damaged.**

It may cause an electric shock.



- **Do not perform any wiring work when the main cable is live.**

It may cause an electric shock, and a damage or a fire by the charged voltage of the converter.



- **Do not disassemble the product even if the power is not on, except for wiring or maintenance.**

It may cause an electric shock by the charged current in the product.



- **Let the electrical technician to perform wiring, test run, and maintenance.**

Otherwise, it may cause an electric shock or a fire by a wrongful operation.



- **Perform terminal work when cutting a cable.**

Otherwise, it may cause an electric shock from the naked part of the cable.



- **Place the terminal cover on the terminal in the back after the wiring work.**

Otherwise, it may cause an electric shock.



CAUTION



- **Apply the rated power to the power source terminal.**
Otherwise, it may cause a damage to the product or a fire.



- **Follow the rated load on the input and output connections.**
Otherwise, it may cause a damage to the product or a fire.



- **Prevent screws, metal parts, water, or oil from entering the product.**
It may cause a damage to the product or a fire.



- **Do not let the product be exposed to a direct sunlight.**
It may cause a damage to the product.



- **Extract and insert Case on a leveled surface.**
Otherwise, it may cause a damage to the product.



- **Do not store the product in a humid or a dusty area.**
It may cause a damage to the product.

REVISIONS

REV	Date	Description / Reason
1.00	2009. 03. 10	User manual approval, registration
1.10	2009. 07. 29	PC Software Program changed
1.11	2012. 08. 23	Product design changed
1.12	2013. 08. 05	Add OP MODE in UVR Element
1.13	2013. 12. 30	Product Shipping Setting Value changed
1.14	2014. 02. 14	LI Curve characteristic value changed
1.15	2015. 03. 13	Edit phrases related OVGR
1.16	2015. 11. 23	PC Software Program Upgrade

CONTENTS

1. Overview	10
1.1 Relay Introduction	10
1.2 Relay Range of Application	10
1.3 Relay Characteristic	11
2. General Specification Data	12
2.1 Rated Control Source Voltage	12
2.2 Voltage	12
2.3 Current	12
2.4 Output Contacts	13
2.5 Input Contacts	13
2.6 Communication	13
2.7 Case	13
2.8 Test	14
2.8.1 Insulation Test	14
2.8.2 Noise Test	15
2.8.3 Mechanical Test	16
2.8.4 Temperature and Humidity Test	16
2.9 Use Environment	16
2.10 Protection Element	17
2.10.1 Time Over-Current Element (TOCR, 51)	17
2.10.2 Instantaneous Over-Current Element (IOCR, 50)	17
2.10.3 Time Ground Over-Current Element (TOCGR, 51N)	17
2.10.4 Instantaneous Ground Over-Current Element (IOCGR, 50N)	18
2.10.5 Direction Time Ground Over-Current Element (TDOCGR, 67N)	18
2.10.6 Direction Instantaneous Ground Over-Current Element (IDOCGR, 67N)	19
2.10.7 Select Ground Element (SGR, 67G)	19
2.10.8 Over-Voltage Element (OVR, 59)	20
2.10.9 Under-Voltage Element (UVR, 27)	20
2.10.10 Time Ground Over-Voltage Element (TOVGR, 64(59G))	20
2.10.11 Instantaneous Ground Over-Voltage Element (IOVGR, 64(59G))	21
2.10.12 Negative Phase Sequence Over-Voltage Element (NSOVR, 47)	21
2.11 Additional Function	22
2.11.1 Measurement	22
2.11.2 CB Control	22
2.11.3 Event Record	23
2.11.4 Fault Waveform Record	23
2.11.5 Self Diagnosis	24
2.11.6 RS-232C Communication	24
2.11.7 RS-485C Communication	25

3. Relay Operation Control Reference	25
3.1 Front Side Display Panel Structure	25
3.1.1 LED / LCD	26
3.1.2 Key Pad / RS-232C / Drawout Handle	26
3.2 Initial Display and Menu Configuration Display	27
3.2.1 Initial Display Status, Backlight On/Off	27
3.2.2 LED Latch Status Clear	27
3.2.3 Menu Configuration Display	27
3.3 CB Status Display and Control	30
3.3.1 CB Status Display	30
3.3.2 LOCAL / REMOTE Control	30
3.3.3 Circuit Breaker Close/Open Control	31
3.4 DISPLAY Function Control	31
3.4.1 Measurement Display	31
3.4.2 Relay Status	34
3.4.2.1 STATUS ► DIGITAL INPUT	34
3.4.2.2 STATUS ► CONTACT OUTPUT	34
3.4.2.3 STATUS ► SELF DIAGNOSIS	34
3.4.2.4 STATUS ► PROT CONDITION	35
3.4.2.5 STATUS ► RS-485 MONITOR	35
3.4.3 Relay Record	35
3.4.3.1 RECORD ► EVENT	35
3.4.3.2 RECORD ► WAVEFORM	39
3.4.3.3 RECORD ► CB OPEN CNT	39
3.4.4 Relay Version (SYS INFO)	39
4. Setting Description	40
4.1 PROTECTION	41
4.1.1 Over-Current Protection (OCR : 50/51)	41
4.1.2 Ground Over-Current, Direction Ground Over-Current Protection (OCGR : 50/51N, DOCGR : 67N)	44
4.1.3 Select Ground Over-Current Protection (SGR : 67G)	48
4.1.4 Over-Voltage Protection (OVR : 59)	49
4.1.5 Under-Voltage Protection (UVR : 27)	51
4.1.6 Ground Over-Voltage Protection (OVGR : 64(59G))	52
4.1.7 Negative Phase Sequence Over-Voltage Protection (NSOVR : 47)	53
4.2 SYSTEM	54
4.2.1 POWER SYSTEM	54
4.2.1.1 POWER SYSTEM ► FREQUENCY	54
4.2.1.2 POWER SYSTEM ► PT CONNECT	54
4.2.1.3 POWER SYSTEM ► PT Ratio	55
4.2.1.4 POWER SYSTEM ► PT SEC	55
4.2.1.5 POWER SYSTEM ► CT Ratio	55
4.2.2 CB CONTROL	56

4.2.3 T/S OUTPUT	56
4.2.3.1 T/S OUTPUT ► CONNECTION	57
4.2.3.2 T/S OUTPUT ► RESET	57
4.2.3.3 T/S OUTPUT ► DELAY	57
4.2.4 SYSTEM TIME	61
4.2.5 WAVEFORM RECORD	61
4.2.6 COMMUNICATION	62
4.2.7 PASSWORD	62
4.3 RECORD CLEAR Function Control	63
4.3.1 CLEAR EVENT	63
4.3.2 CLEAR WAVEFORM	63
4.3.3 CLEAR ENERGY	64
4.3.4 SET CB OPEN COUNTER	65
4.4 TEST Function Method	65
4.4.1 DISPLAY TEST	65
4.4.2 CONTACT TEST	66
5. PC Software	67
5.1 KBIED_MNE	67
5.1.1 Application Software Program Install method	67
5.1.2 KBIED_MNE Program Menu	68
5.1.3 Create Project (Edit Devices)	69
5.1.3.1 Station	70
5.1.3.2 Device	71
5.1.3.3 Project Window	72
5.1.3.4 Save/Open Project	73
5.1.3.5 Save Device	73
5.1.3.6 Setting window menu	74
5.1.4 Direct Connect	75
5.1.5 Write Device saved Settings Files	76
5.1.6 Print/Print preview	77
5.1.7 Compare Device Settings with Settings File	78
5.1.8 Export Setting File	78
5.1.9 Event	79
5.1.10 Waveform	79
5.1.11 Power Quantity	80
5.1.12 Status	81
6. Install and Connection	84
6.1 Dimensioned Drawings	84
6.2 Rear Terminal Layout	85
6.3 External Connection	86
6.3.1 K-PAM F300 External Connection	86
6.3.2 K-PAM F300 PT Connection	87

6.3.3 K-PAM F300 CT Connection	89
6.3.4 Input/Output Contacts Connection	91
6.3.5 RS-232C Commnication Port Connection	92
6.3.6 RS-485C Commnication Port Connection	92
6.4 Separation and Replacement of Module	93
6.4.1 Separation of Module	93
6.4.2 Replacement of Module	93
Appended 1. Characteristic Curve	94
Appendix A. Product Shipping Setting Values	107
Appendix B. External Connection by Product Shipping Setting Values	110

1. Overview

1.1 Relay introduction

K-PAM F300 is multi-function relay for Feeder protection, regardless of the ground system(direct grounding, non grounding, resistance grounding) used for back-up protection/control/observation of distribution line and transformer.

And relay designed and manufactured to be able to protect device and all line as breaking or warning to line when fault occurred.

Event/fault waveform record function provide data for fault analysis and operation record of relay, Event/fault waveform record data is stored permanently even if the power is lost. Stored record can analyze to pc screen through front RS-232C communication port, used KBIED_MNE.

K-PAM F300 provide convenient menu tree through LED, LCD and relay can control by operate relay front key.

Relay rear side has RS-485C port connected remote supervisory control system, remote system communication protocol has ModBus(RTU).

1.2 Relay application

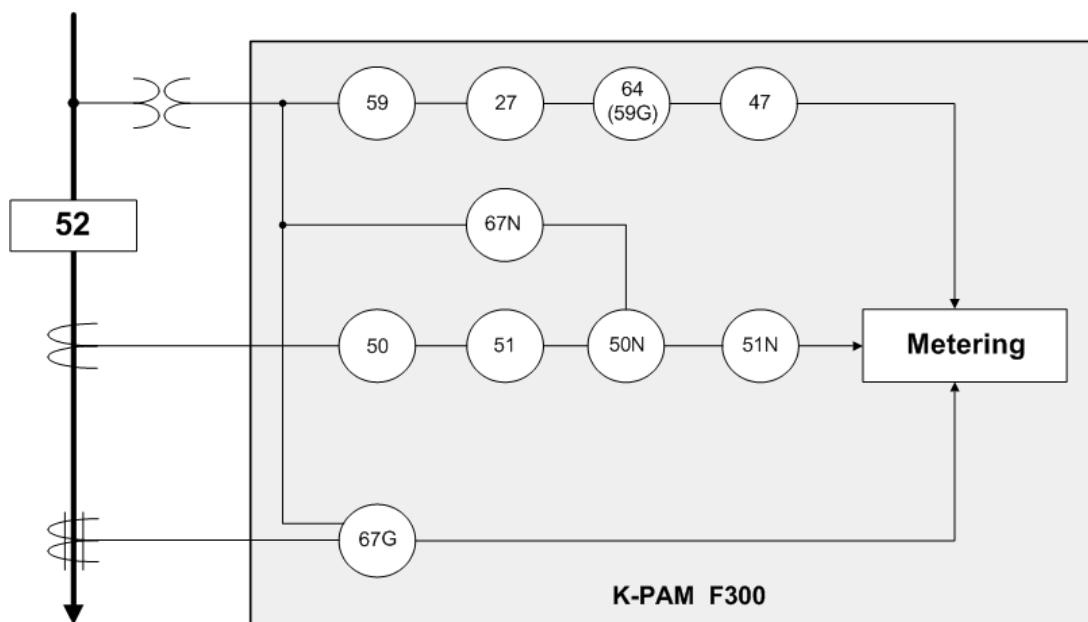

< figure 1. Function Diagram >

Device	Function
50/51	over-current protect
50N/51N	ground over-current protect
67N	directional ground over-current protect
67G	select ground over-current protect
59	over-voltage protect
27	under-voltage protect
64(59G)	ground over-voltage protect
47	reverse phase over-voltage protect

1.3 Relay characteristic

- Digital Feeder protection multi-function relay used DSP processor
- Protection relay element : OCR, OCGR, DOCGR, SGR, OVR, UVR, OVGR, NSOVR.
- Realization of various time characteristics : IEC standards, KEPCO.
- Circuit Breaker can be controlled Open/Close, Local/Remote.
- Electricity Measurement Function: 3 Phase Current/Voltage, Sequence Current/voltage, 3 Phase Active/Reactive/Complex Power, Energy, Frequency, Power Factor.
- Output contact TEST is possible through relay inside manual Trip command.
- When setting change and circuit breaker control, maintain tight security through input password
- 1024 event record and max 6 fault wave record (32 Sample/Cycle)
- Provided free of charge PC Tool of powerful function : Setting Change, Event Data Check, Fault Wave Analysis, Relay State and Electricity Measurement, Monitoring of input, output contact
- Set value and measured values are Displayed digitally through LCD Display. (4 × 20 LCD Screen)
- Various communications supported
 - Front : RS-232C (ModBus RTU Protocol : setting value change, Event/fault waveform transmission, electricity measurement and relay state observation)
 - Rear : RS-485C (ModBus RTU : SCADA communication)
- Self diagnosis function : Control power, Memory, CPU, setting value range, A/D Converter, analog input circuit and digital input/output circuit.
- Relay Software upgrade used Flash Memory is easy.
- Control power free select : AC / DC 110 ~ 220V
- 10 Relay contact output (T/S Output) can be set to each 55 mode and can use

all Alarm.

-Trip contact(3a), Single contact(6a, 1b)

- When relay occur error, operation reliability improvement through output contact.
- Increased EMC / EMI performances.
- Applied standards : KEMC 1120 (2008. 06. 26), IEC 60255.

2. General Specification Data

2.1 Rated Control Power

Rated control power	AC/DC 110 ~ 220V (free voltage)	
Overload	1.3Time/3h of rated Voltage	
Burden	Normal	30W or less
	Operation	70W or less

2.2 Voltage

Rated voltage	AC 63.5 ~ 190V
Overload	1.15Time/3h of rated Voltage
Burden	0.5VA or less / Phase

2.3 Current

Rated Current	current	AC 5A
	zero phase current	AC 1.5 mA
Overload	current	2times of rated current / 3h 20times of rated current / 2sec 40times of rated current / 1sec
	zero phase current	100times of rated current / Continuous
Burden	0.5VA or less / Phase	

2.4 Output contacts

TRIP : T/S1 ~ T/S3 Contacts(1a×3)	
Close Circuit Capacity	16A / Continuous / AC 250V 30A / 0.3sec / DC125V / Resistance load
Opening Capacity	5A / 0.1(PF) / AC 250V
SIGNAL : T/S4 ~ T/S9 Contacts(1a×6), T/S10 Contacts (1b×1)	
Close Circuit Capacity	5A / Continuous / AC 250V 5A / 0.3sec / DC125V / Resistance load
Opening Capacity	1A / 0.1(PF) / AC 250V 1A / 25ms (L/R Time constant), DC 125V

2.5 Input contacts

Number	2 Point
Input voltage	Max AC / DC 250V
Contacts reflect time	10ms or less

2.6 Communication

Front RS-232C	1 (Maintenance / KBIED_MNE) 19200Bps(Fixed), 8Bit / No Parity / 1 Stop
Back RS-485C	1 (For SCADA Communication / Modbus) 300 ~ 19200Bps, 8Bit / No Parity / 1 Stop

2.7 Case

Structure	Draw-Out Type
Color	Munsell No. N1.5 (Black)
Material	Fe
Port	U(Spade) / Ring Lug ID : 5mm, Max OD : 12mm

2.8 Test

2.8.1 Insulation Test

Insulation resistance	DC 500V	Electrical circuit to gorund	10MΩ	IEC60255 -5
		Electrical circuit between interaction	5MΩ	
		Electrical circuit between terminals		
Commercial Frequency Withstand Voltage	50/60Hz, 1min	Bulk electrical circuit to gorund	2kV	IEC60255 -5
		Electrical circuit between interaction		
		Bulk communication circuit to gorund		
		Contacts circuit between terminals	1kV	
Impulse Withstand Voltage	1.2/50μs, + · -Polarity, 3Time	Bulk electrical circuit to gorund	5kV	IEC60255 -5
		Transformer circuit between interaction		
		Transformer circuit between control circuit		
		Control circuit between interaction	3kV	
		Transformer circuit between terminals		
		Control power circuit between terminals		

2.8.2 Noise Test

1MHz burst disturbance	Vibration Frequency : 1MHz Voltage rise time : 75ns Repetition frequency : 400Hz Output impedance : 200Ω Apply method : Asynchronous	Common mode	2.5kV	IEC60255-22-1
		Differential mode	1.0kV	
EFT / Burst	Voltage rise time : 5ns Repetition frequency : 2.5kHz Burst duration : 15ms Burst cycle : 300ms Input, Pause Time : 1Min	Electrical circuit	4kV	IEC60255-22-4 Class A
		Communication circuit	2kV	
Electrostatic Discharge	Apply times : 10 times Apply interval : 1sec Apply part : Case	Air discharge	8kV	IEC60255-22-2 Class III
		Contact discharge	6kV	
Lighting Surge	Voltage waveform : 1.2×50μs Current waveform : 8×20μs output impedance : 2Ω,12Ω Apply interval : 30sec Apply times : 3times	Common mode	2.0kV 1.0kV 0.5kV	IEC60255-22-5
		Differential mode	1.0kV 0.5kV	
Radio Frequency Radiation Endurance	80MHz ~ 1GHz, 10V/m, 1sec			IEC60255-22-3
Radio Frequency Conduction Endurance	150kHz ~ 80MHz, 10V, 1sec			IEC60255-22-6

2.8.3 Mechanical Test

Vibration	Vibration Response	10 ~ 150Hz, 0.5G, Front/Rear, Left/Right, Up/Down 1 time	IEC60255-21-1 Class 1
	Vibration Endurance	10 ~ 150Hz, 1G, Front/Rear, Left/Right, Up/Down 20 times	
	Shock	Shock Response	5G, Front/Rear, Left/Right, Up/Down 3 times
Shock Withstand		15G, Front/Rear, Left/Right, Up/Down 3 times	
Bump		10G, Front/Rear, Left/Right, Up/Down 1000 times	
Earthquake	1 ~ 8.5Hz	x : 3.5mm, y : 1.5mm, Sweep : 1time	IEC60255-21-3 Class 1
	8.5 ~ 35Hz	x : 1G, y : 0.5G, Sweep : 1time	

2.8.4 Temperature, Humidity Test

Standard	IEC 60068-2-1/2
Operation temperature	-25℃ ~ 70℃
Storage temperature	-30℃ ~ 75℃
Relativity Humidity	RH 30 ~ 95%

2.9 Operation condition

Altitude	1000m Less
Etc.	Condition where there is no abnormal vibration, shock, slope or influence of the magnetic field Place where there is no explosive dust, flammable dust, or flammable / rusty gas, or salt

2.10 Protection element

2.10.1 TOCR, 51

Operation value	0.2 ~ 16A (0.1A Step)
Definite time operation time	0.04 ~ 60.00Sec (0.01Sec Step)
TM	0.05 ~ 10.00 (0.05 Step)
Operation characteristic	NI, VI, EI, LI, KNI, KVI, KLNI, KLVI, DT
Release Delay Time	0.00 ~ 200.00Sec (0.01Sec Step)
Release Value	Over 95% of Setting Value
Operation Accuracy	Less than $\pm 3\%$ of Setting Value

2.10.2 IOCR, 50

Operation value	1.0 ~ 100.0A (0.5A Step)
Instantaneous operation time	$\leq 40\text{ms}$
Definite time operation time	0.04 ~ 60.00Sec (0.01Sec Step)
Release Delay Time	0.00 ~ 200.00Sec (0.01Sec Step)
Release Value	Over 95% of Setting Value
Operation Accuracy	Less than $\pm 3\%$ of Setting Value

2.10.3 TOCGR, 51N

Operation value	0.1 ~ 10.0A (0.1A Step)
Definite time operation time	0.04 ~ 60.00Sec (0.01Sec Step)
TM	0.05 ~ 10.00 (0.05 Step)
Operation characteristic	NI, VI, EI, LI, KNI, KVI, KLNI, KLVI, DT
Release Delay Time	0.00 ~ 200.00Sec (0.01Sec Step)
Release Value	Over 95% of Setting Value
Operation Accuracy	Less than $\pm 3\%$ of Setting Value

2.10.4 IOCGR, 50N

Operation value	0.5 ~ 50.0A (0.1A Step)
Instantaneous operation time	≤ 40ms
Definite time operation time	0.04 ~ 60.00Sec (0.01Sec Step)
Release Delay Time	0.00 ~ 200.00Sec (0.01Sec Step)
Release Value	Over 95% of Setting Value
Operation Accuracy	Less than ±3% of Setting Value

2.10.5 TDOCGR, 67N

Current operation value	0.1 ~ 10.0A (0.1A Step)
Voltage Operation value	5 ~ 170V (1V Step)
Direction	FORWARD, REVERSE
MTA	-90° ~ 90° (1° Step)
Operation phase angle	MTA ± 90°
Definite time operation time	0.04 ~ 60.00Sec (0.01Sec Step)
TM	0.05 ~ 10.00 (0.05 Step)
Operation characteristic	NI, VI, EI, LI, KNI, KVI, KLNI, KLVI, DT
Release Delay Time	0.00 ~ 200.00Sec (0.01Sec Step)
Release Value	Over 95% of Setting Value
Operation Accuracy	Less than ±3% of Setting Value

2.10.6 IDOCGR, 67N

Current operation value	0.5 ~ 50.0A (0.1A Step)
Voltage Operation value	5 ~ 170V (1V Step)
Direction	FORWARD, REVERSE
MTA	-90° ~ 90° (1° Step)
Operation phase angle	MTA ± 90°
Instantaneous operation time	≤ 40ms
Definite time operation time	0.04 ~ 60.00Sec (0.01Sec Step)
Release Delay Time	0.00 ~ 200.00Sec (0.01Sec Step)
Release Value	Over 95% of Setting Value
Operation Accuracy	Less than ±3% of Setting Value

2.10.7 SGR, 67G

Current operation value	0.9 ~ 250.0mA (0.1mA Step)
Voltage Operation value	5 ~ 170V (1V Step)
MTA	-90° ~ 90° (1° Step)
Direction	FORWARD, REVERSE
Operation phase angle	MTA ± 90°
Definite time operation time	0.04 ~ 60.00Sec (0.01Sec Step)
TM	0.05 ~ 10.00 (0.05 Step)
Release Delay Time	0.00 ~ 200.00Sec (0.01Sec Step)
Release Value	Over 95% of Setting Value
Operation Accuracy	Less than ±3% of Setting Value

2.10.8 OVR, 59

Operation value	5 ~ 170V (1V Step)
Definite time operation time	0.04 ~ 60.00Sec (0.01Sec Step)
TM	0.05 ~ 10.00 (0.05 Step)
Release Delay Time	0.00 ~ 200.00Sec (0.01Sec Step)
Release Value	Over 95% of Setting Value
Operation Accuracy	Less than $\pm 3\%$ of Setting Value

2.10.9 UVR, 27

Operation value	5 ~ 170V (1V Step)
Definite time operation time	0.04 ~ 60.00Sec (0.01Sec Step)
TM	0.05 ~ 10.00 (0.05 Step)
Release Delay Time	0.00 ~ 200.00Sec (0.01Sec Step)
Release value	Over 95% of Setting Value
Operation Accuracy	Less than $\pm 3\%$ of Setting Value

2.10.10 TOVGR, 64(59G)

Operation value	5 ~ 170V (1V Step)
Definite time operation time	0.04 ~ 60.00Sec (0.01Sec Step)
TM	0.05 ~ 10.00 (0.05 Step)
Operation characteristic	NI_TRIP NI_ALARM DT
Release Delay Time	0.00 ~ 200.00Sec (0.01Sec Step)
Release value	Over 95% of Setting Value
Operation Accuracy	Less than $\pm 3\%$ of Setting Value

2.10.11 IOVGR, 64(59G)

Operation value	10 ~ 170V (1V Step)
Instantaneous operation time	≤ 40ms
Definite operation time	0.04 ~ 60.00Sec (0.01Sec Step)
Release Delay Time	0.00 ~ 200.00Sec (0.01Sec Step)
Release value	Over 95% of Setting Value
Operation Accuracy	Less than ±3% of Setting Value

2.10.12 NSOVR, 47

Operation value	5 ~ 170V (1V Step)
Definite operation time	0.04 ~ 60.00Sec (0.01Sec Step)
Release Delay Time	0.00 ~ 200.00Sec (0.01Sec Step)
Release value	Over 95% of Setting Value
Operation Accuracy	Less than ±3% of Setting Value

2.11 Additional Function

2.11.1 Measurement

Voltage	3phase voltage / Line-line voltage RMS and Phase Zero sequence voltage rms and phase Measurement range : 0 ~ 300V (when PT Ratio 1:1)
Phase current	Current rms and phase Measurement range : 0 ~ 250A (when CT Ratio 5:5)
ZCT Current (Is)	ZCT secondary zero sequence current rms and phase Only use ZCT Measurement range : 0 ~ 1000mA
Sequence Voltage	Positive sequence, Negative sequence, Zero sequence voltage RMS and Phase
Sequence Current	Positive sequence, Negative sequence, Zero sequence current RMS and Phase
Frequency	A phase Voltage standard Measurement range : 30.000 ~ 100.000Hz
Power	Each phase / 3Phase Active Power (0 ~ 62500W) Each phase / 3Phase Reactive Power (0 ~ 62500Var) Each phase / 3Phase Complex Power (0 ~ 62500VA)
Wattage	3 phase Active / Reactive Wattage
PF	Each phase / 3phase PF

2.11.2 Circuit breaker control

Number	1CB
LOCAL Control	Misoperation prevention according to password input Control through control Keypad
REMOTE Control	Control through rear RS-485C communication port

2.11.3 Event Record

Max Record	1024
Resolution	10ms unit
Event category	Protection relay element Pickup / Release / Operation, CB Status change, Self diagnosis ERROR occurred, SETTING change, Event Clear, Waveform Clear, Energy Clear, Annunciator Reset, Control Power On/Off, Waveform Capture, CB control
characteristic	When Protection relay element Event occurred, electricity record (Time of Event, Voltage, Current Rms and Phase) If it lose control Power, upkeep event data. *.TXT file can be saved

2.11.4 Fault waveform record

Max record	6	
Recording Type	168cycle × 6	
Sampling Number	32Sample/Cycle	
Category Setting	T_POS	0 ~ 99% (1% STEP)
	T_SRC	OP, PKP, OP+PKP
In / Is	In / Is	
PC Display Category	Each phase current (size, phase, harmonic, distortion) Each phase voltage (size, phase, harmonic, distortion) Zero sequence current (In or Is) Contact output state Contact input state Protection relay element state	
Relay display category	Trigger time, T_SRC, Protection relay element, Recording Type	
Data Saving	If it lose control Power, upkeep event data. *.cfg, *.data file can be saved Comtrade file Format(IEEE C37.111) format	

2.11.5 Self diagnosis

Category	DC Power, CPU Watchdog, Memory, Setting Error, A/D Converter Error, DI/O Circuit
Display error occurred	Front Red ERROR LED or SYSTEM_ERR Display contact output use T/S OUTPUT correction

2.11.6 RS-232C Communication

The RS-232C communication cable supplied with this product uses a cross cable which has NO.2 and NO.3 pins crossed, so using ordinary direct cable will not enable the communication.

If there is no RS-232C port in the PC and uses USB port, only with USB to 232 cable cannot make connection, so please use USB to 232cable with the cross cable supplied with this product together.

Protocol	Communication Method	<ul style="list-style-type: none"> ● RS-232 / RS-485
	Support Protocol	<ul style="list-style-type: none"> ● MODBUS
Communication Standard (RS-485C)	Communication Distance	<ul style="list-style-type: none"> ● 1.2km
	Communication line	<ul style="list-style-type: none"> ● General RS-485C Two-Pair cable
	Communication Speed	<ul style="list-style-type: none"> ● 300 ~ 19,200 bps
	Communication method	<ul style="list-style-type: none"> ● Half-Duplex
	Max Input/Output voltage	<ul style="list-style-type: none"> ● -7V ~ +12V
Communication Port	LCD Display	<ul style="list-style-type: none"> ● RS232 Port 1 ● 19200 BPS Fix, MODBUS Protocol
	Rear	<ul style="list-style-type: none"> ● RS485 Port 1 ● 300 ~ 19200 BPS, MODBUS Protocol ● Client SCADA Communication ● Terminal Number : 51(+), 52(-), 53(Com)

2.11.7 RS-485C Communication

Relay provides insulated RS-485 Half Duplex Communication method for the connection to the Upper level monitoring control system.

This communication method can connect as multidrop, maximum communication distance is 1.2km. End of RS-485 line connected in parallel to resistance 120Ω.

3. Operational Description

3.1 Front Display Panel Composition

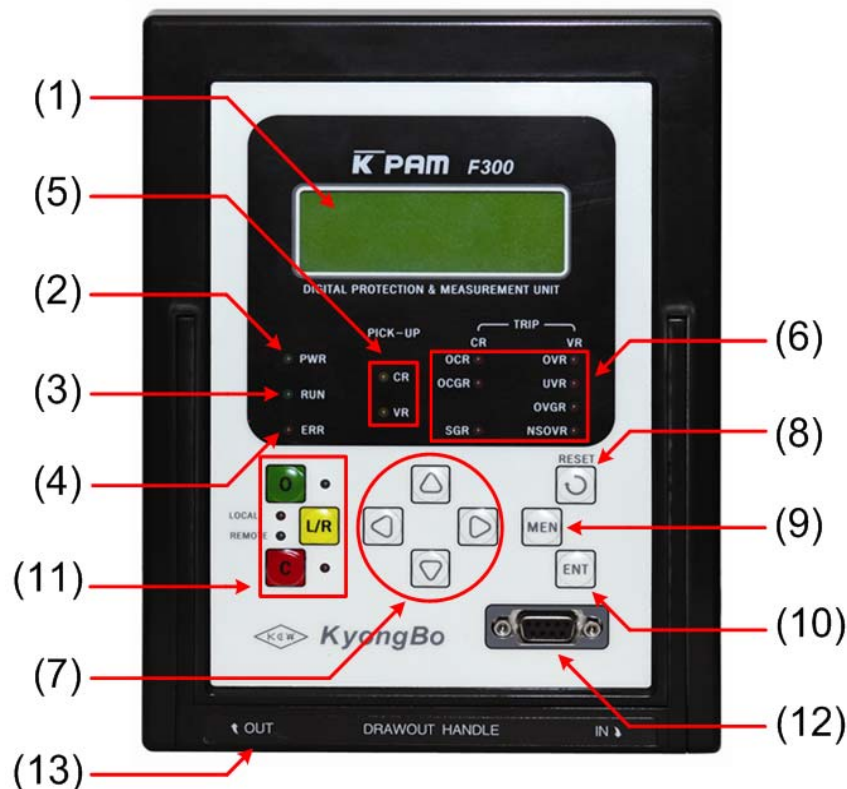

Front display panel of K-PAM F300 is composed of LCD(4×20), 16 LED, 10 Keypad and RS-232C communication port. There is a transparent cover on the Relay front part to protect Relay from dust and foreign objects, and protects the Relay front part from the damage that may be caused by the user's mistakes. Also, password is required to change setting value or CB control to prohibit anyone other than the designated user from changing the Settings. Protection function is still performed while control the operation status through LCD

Besides using KeyPad operation, if you connect the KBIED_MNE(PC Software) using front RS-232C port, you can change setting, Event/fault waveform transmission, etc. more conveniently.













< Figure 2. Front Display Panel >

3.1.1 LED / LCD Function

LED / LCD		Function	
(1) LCD		Setting value, Measurement value, Operation Display	
(2) PWR	Green	When input control power, LED ON	
(3) RUN	Green	As a LED indicating that the power is supplied and the CPU of the protection relay is running normally, it is lighted in normal condition.	
(4) ERR	Red	When relay self diagnosis error, LED ON Return to LED state by manual reset through “RESET”() Key	
(5) Pick-Up	Yellow	When protection element pick-up, LED ON.	
(6) TRIP	Red	When Protection element(OCR, OCGR, DOCGR, SGR, OVR, UVR, OVGR, NSOVR) operate, LED ON. Return to LED state by manual reset through “RESET”() Key	
(11) CB Control	Local	Red	Local / Remote display state can be controlled
	Remote	Green	
	OPEN	Green	When CB is open, LED ON
	CLOSE	Red	When CB is close, LED ON

3.1.2 Key Pad / RS-232C / Drawout handle

KeyPad		Function
(7) Direction Key	 (UP)	Move Menu, Change setting range
	 (DOWN)	Move Menu, Change setting range
	 (RIGHT)	Move Menu, Select menu category
	 (LEFT)	Move Menu, ESC(Move top menu, Cancel category)
(8)  (RESET)		“ERROR” LED and “TRIP” LED manual reset
(9)  (MENU)		Move Initial Display to Menu Tree Display
(10)  (ENTER)		Input setting value and Command Menu Yes/No Confirm
(11) Control	 (Local/Remote)	Local/Remote change control position
	 (OPEN)	Control CB Open
	 (CLOSE)	Control CB Close
(12) RS-232C Port		Connect KBIED_MNE
(13) Drawout Handle		Handle used for relay drawout

3.2 Initial Display and Menu Configuration Display

3.2.1 Initial Display State, Backlight On/Off

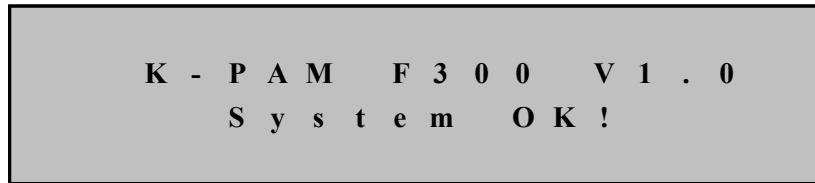

< Figure 3. Initial Display >

When there is a fault in the relay, "System Error" is Displayed instead of "System OK". The Backlight of LCD will turn Off automatically after 3 minutes without button operation, circulated measured values automatically

3.2.2 LED Latch State Clear

■ OCR/OCGR/SGR/OVR/UVR/OVGR/NSOVR LED Clear

If operating as protection element LATCH LED, LED ON until you pressing RESET() Key

If pressing RESET() Key, LED Clear when all protection/detection element returned status.

■ “ERROR” LED Clear

“ERROR” LED is representative LED of self diagnosis state display, If one or more self diagnosis element operate, LED ON.

If pressing RESET() Key, “ERROR” LED Clear when all self diagnosis element returned status.

3.2.3 Menu Composition Display

Menu composition display is divided to DISPLAY MODE BLOCK(Status, Metering, Record, SYS info etc.) and SETTING MODE(set/display the correction of Relay and Protection, active/reactive energy and event, initialization of fault waveform data, OPEN count setting of CB, Test of output contact, Relay front test etc.).

■ Menu-tree Key control

If you press the MENU(MEN) Key in initial screen, switched menu composition screen. Select the want menu through UP(Δ), DOWN(▽), RIGHT(▶), LEFT(◀) Key, refer to menu composition screen.

Example 1) When initial screen move from event screen

MENU(MEN) Key ⇒ RIGHT(▶) DISPLAY MODE ⇒ RIGHT(▶) Key (Measurement) ⇒ DOWN(▽) Key(Status) ⇒ DOWN(▽) Key(RECORD) ⇒ RIGHT(▶) Key(EVENT Record) ⇒ RIGHT(▶) Key(EVENT)

Total menu composition of K-PAM F300 is as follows

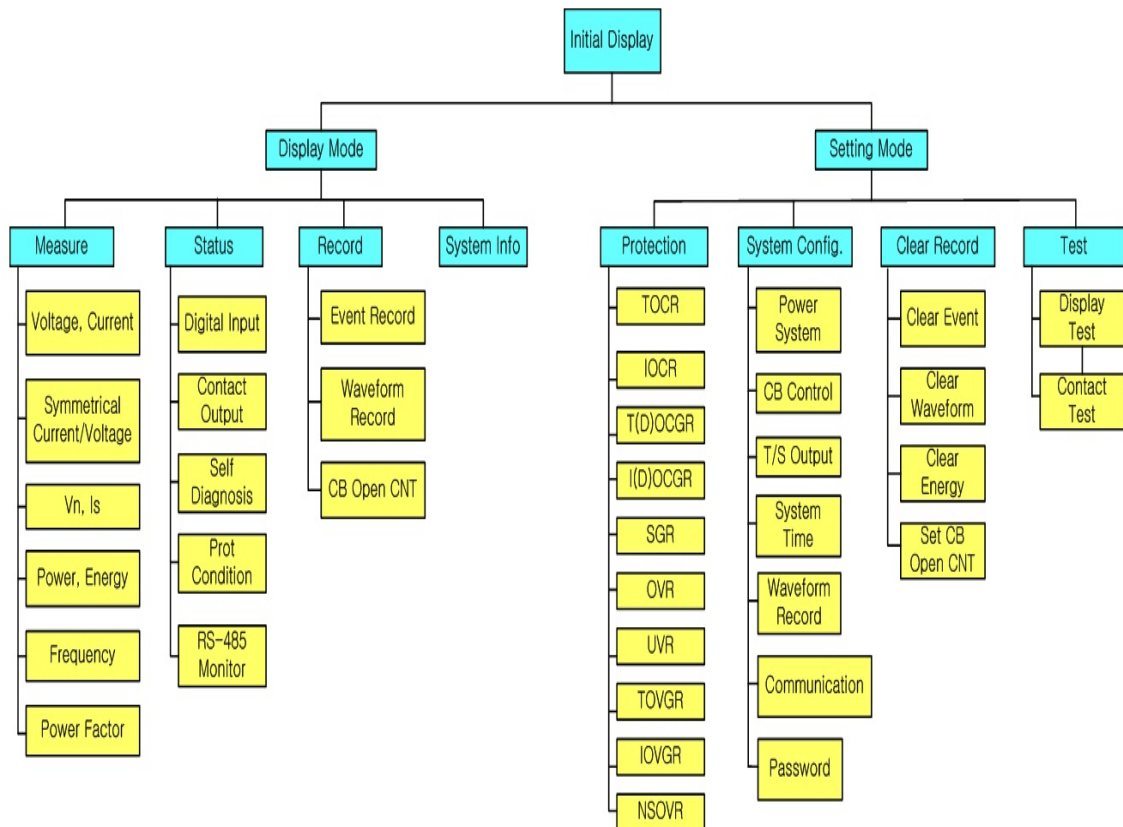

< figure 4. F300 Menu Tree >

Detail categories description of menu composition categories is as follows

I n i t i a l D i s p l a y	DISPLAY	Measurement		Electricity Measurement
		STATUS	DIGITAL INPUT	Contact Input state
			CONTACT OUTPUT	Contact output state
			SELF_DIAGNOSIS	Self diagnosis state
			Prot Condition	Protection element state
			RS-485 Monitor	RS-485 communication state
		RECORD	EVENT	Event occurrence list
			WAVEFORM	Fault waveform save list
			CB OPEN CNT	Number of CB OPEN COUNTER
		SYS INFO		DSP S/W Version Information
	SETTING	Protection	OCR(50/51)	Short circuit over-current protection correction
			OCGR(50N/51N,67N)	(Direction)Ground over-current protection correction
			SGR(67G)	Select Ground over-current protection correction
			OVR(59)	Over-voltage protection correction
			UVR(27)	Under-voltage protection correction
			OVGR(64(59G))	Ground Over-voltage protection correction
			NSOVR(47)	Reverse phase over-current protection correction
		SYSTEM	POWER SYSTEM	Power System and Wiring Correction
			CB CONTROL	CB State Display and Control Correction
			T/S OUTPUT	T/S Contact Correction
			SYSTEM TIME	Relay Time Correction
			Waveform Record	Fault Waveform Record Correction
			COMMUNICATION	RS-485 Communication Correction
			PASSWORD	Correction/Control Password Correction
		Record Clear	Clear Event	Event Data Clear
			Clear Waveform	Fault Waveform Data Clear
			Clear Energy	Energy Data Clear
SET CB OPEN CNT			Set CB Open Count	
TEST		DISPLAY Test	Relay Front LCD / LED Test	
		CONTACT Test	Contact Output Test	



3.3 CB Status Display and Control

When SETTING/SYSTEM/CB Control function set to "ENABLE", you can control the Circuit Breaker.

If you want change a CB control and LOCAL/REMOTE on the spot, KEY_CONTROL category must set to "ENABLE".

3.3.1 CB Status Display

Status display of CB can be check by LED. And status of CB can be check by inputted status of 52a contact and 52b contact as input contact.

LED State		CB State
CB OPEN() LED	CB CLOSE() LED	
ON	OFF	CB OPEN STATE
Flash	Flash	CB ERROR STATE
OFF	OFF	CB Function DISABLE
OFF	ON	CB CLOSE STATE



3.3.2 LOCAL / REMOTE Control

If you control the CB on the spot, control authority should be Local, If you control the CB in remote through RS-485C communication, control authority should be Remote.

Change the CB control authority is available only on the spot.

If you change the control authority setting, control authority change by pressing Local/Remote() Key.

CB control authority change is as follows.

Local/Remote() Key ⇒ Input Password ⇒ ENTER() Key ⇒

Local/Remote() Key

After input password, If you pressing the ENTER() Key, LCD display CB status(OPEN, CLOSE, TROUBLE) and CB control authority status.









When CB control authority changed, you can be check immediately by LED.

If you want to move the initial display, press the LEFT() Key or after 1minute to

move to the initial display.

3.3.3 Circuit Breaker Open/Close Control

If you control(Open/Close) the CB on the spot, operate keys as follows on control authority of CB is Local

OPEN Key() or CLOSE Key() ⇒ Input Password ⇒ ENTER() Key ⇒ According to the user's intent OPEN Key() or CLOSE Key() ⇒ LCD screen display a final CB OPEN / CLOSE selection screen, flash a "NO", "YES". ⇒ Change the "YES" using UP() or DOWN() Key ⇒ Output Using ENTER() Key

After input password, If you press the ENTER() Key, LCD display a present CB status(OPEN, CLOSE, TROUBLE) and status of CB control authority.

If you want to finish CB OPEN/CLOSE control, press the LEFT() Key then move to initial screen or after 1minute without pressing any key, move to initial screen.

If you select "NO" from screen finally asking a output, does not output.

If you pressing the ENTER() Key form "YES", output contacts set to control command operated. When Local CB control, you must input Password.

If you want CB control by Remote, control authority of CB set to Remote through CB control authority method. And CB can be controlled from upper level communication and SCADA through RS-485C communication.

3.4 DISPLAY Function control

Display can be checked the measurement of electricity, input/output state of contact, self diagnosis state, operation state of protection element, event and fault wave form, version information of relay.

3.4.1 Display measurement

DISPLAY/Measurement can be checked the various measurements.

If PT connection is NONE, standard of phase display is A phase current, If PT

connection is WYE or DELTA, A phase voltage is standard, size of voltage/current/power display to 1 side value applied by PT ration, CT ratio.

If PT connection is WYE, voltage display to line-line voltage through relay internal arithmetic because of relay input voltage is recognized as phase voltage.

And if PT connection is DELTA, phase voltage does not display because of relay input voltage is recognized line-line voltage, zero sequence voltage size display to 0.

Each phase, active/reactive/complex power of 3 phase display measurement value only if PT connection is WYE. Calculation method is as follows.

Active Power : $P = V \times I \times \cos\theta$, Reactive Power: $Q = V \times I \times \sin\theta$,

Complex Power : $S = V \times I$

If PT connection is DEL, display 3 phase active/reactive/complex power size, size of each phase display to 0.

Calculation method of sequence voltage/current is as follows

$$\underline{\text{Zero sequence voltage value} = \frac{1}{3} (\mathcal{V}_A + \mathcal{V}_B + \mathcal{V}_C)}$$

$$\underline{\text{Zero sequence current value} = \frac{1}{3} (\mathcal{I}_A + \mathcal{I}_B + \mathcal{I}_C)}$$

$$\underline{\text{Positive sequence voltage value} = \frac{1}{3} (\mathcal{V}_A + a\mathcal{V}_B + a^2\mathcal{V}_C)}$$

$$\underline{\text{Positive sequence current value} = \frac{1}{3} (\mathcal{I}_A + a\mathcal{I}_B + a^2\mathcal{I}_C)}$$

$$\underline{\text{Negative sequence voltage value} = \frac{1}{3} (\mathcal{V}_A + a^2\mathcal{V}_B + a\mathcal{V}_C)}$$

$$\underline{\text{Negative sequence current value} = \frac{1}{3} (\mathcal{I}_A + a^2\mathcal{I}_B + a\mathcal{I}_C)}$$

$$\Rightarrow \underline{a = 120^\circ, a^2 = 240^\circ}$$

Sign display of Active/Reactive power and PF display is as follows

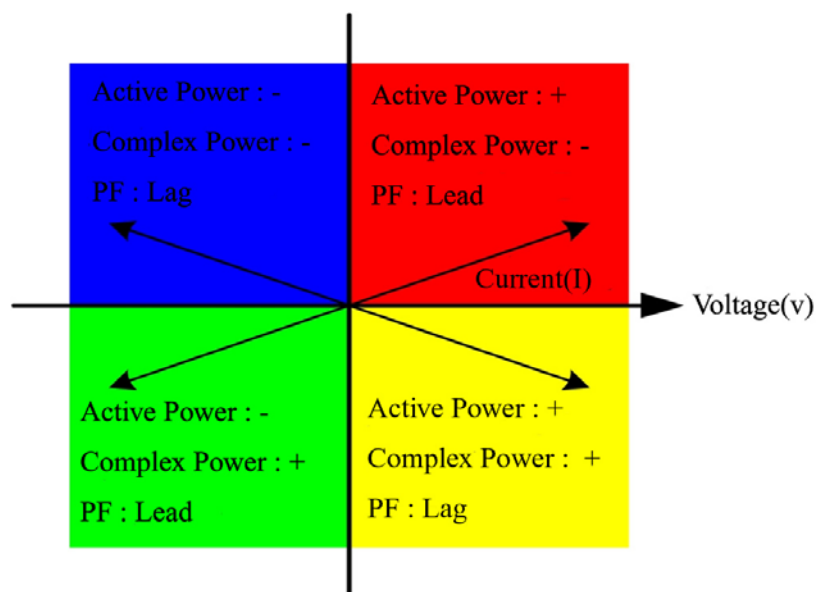



<Figure 5. Sign and PF of Active/Reactive Power>

Measurement display is as follows.

Category	Reference
VA, VB, VC, VN	A Phase, B Phase, C Phase, N Phase, Primary voltage value and phase
VAB, VBC, VCA	AB Phase, BC Phase, C Phase Primary line-line voltage value and phase
IA, IB, IC, IN	A Phase, B Phase, C Phase, N Phase Primary current value and phase
Is	ZCT secondary current value and phase
V0, V1, V2	Primary (zero sequence, Positive sequence, negative sequence) voltage value and phase.
I0, I1, I2	Primary (zero sequence, Positive sequence, negative sequence) current value and phase.
WATT_A, B, C	A Phase, B Phase, C Phase Primary Active power value
WATT_T	3 phase Primary Active power
VAR_A, B, C	A phase, B phase, C phase Primary Reactive power value
VAR_T	3 phase Primary Active power value
VA_A, B, C	A phase, B phase, C phase Primary Complex power value
VA_T	3 phase Primary Complex power value
PF_A, B, C	A phase, B phase, C phase Primary PF value
PF_T	3 phase, Primary PF value
Wath	Active energy
Varh	Reactive energy
FREQ	VA Phase voltage frequency value

3.4.2 Relay Status Display

DISPLAY/STATUS can know the operation status of input/output contacts, self diagnosis status, protection element, operation status of RS-485 communication.

State information can be checked by using UP() , DOWN() Key.

3.4.2.1 STATUS ► DIGITAL INPUT

DISPLAY/STATUS/DIGITAL INPUT can be checked current input state of 52a contact and 52b contact.

If contact input is LOGIC 1, display to "Ene" and if contact input is LOGIC 0, display to "DeE".

3.4.2.2 STATUS ► CONTACT OUTPUT

DISPLAY/STATUS/CONTACT OUTPUT can be checked current output state of contact output 10. If contacts output is operated, display to "Ene". Otherwise, display to "DeE".

3.4.2.3 STATUS ► SELF DIAGNOSIS

DISPLAY/STATUS/SELF DIAGNOSIS can be checked self diagnosis state. Self diagnostic function is to monitor the operation status of the Relay continuously to prevent malfunction of the device. When each category is normality, display "OK", if relay an error is detected, display "ERR" and "ERROR" LED on.

When relay is occurred error, operation of protection element is blocked immediately and error sign display to LCD and LED until an error status is removed.

When the user verifies the error status, take appropriate measures, and the error is fixed, it Displays "System OK" on the front LCD of the Relay, pressing "RESET" () key turns off "ERR" LED on the front of the Relay, and the error category changes to "OK" in the Self Diagnosis of the Status Menu.

If an error occurs in the Relay, user should verify the DISPLAY/STATUS/SELF DIAGNOSIS and find which category has the error in the self diagnosis categories, and call our A/S department, then the user can receive an appropriate measure.

Please refrain from turning Off and On the power of the Relay while the product is in unstable state.

The tel. no. of our A/S department is 82-2-465-1133(extension 129).

The major diagnosis categories are as follows.

- MEMORY
- SETTING
- A/D CONVERTER
- DC POWER
- CPU EXCEPT.
- DO/I CIRCUIT

3.4.2.4 STATUS ► PROT CONDITION

DISPLAY/STATUS/PROT CONDITION can be check Pickup of protection element and operation status. Operation status display is if 3 phase protection element, displayed the phase. If A phase operated, displayed "A", if single phase protection element, displayed "OP".

3.4.2.5 STATUS ► RS-485 MONITOR

DISPLAY/STATUS/RS-485 MONITOR can be check RS-485 communication status separating by TXD and RXD.

When the data were received, RXD category display the "Receive" category, when the data were transmitted, TXD category display the "Send".

3.4.3 Relay Record Display

DISPLAY/RECORD can be check Event occurrence record and saved fault waveform information, CB OPEN Record.

3.4.3.1 RECORD ► EVENT

DISPLAY/RECORD/EVENT can be check event occurrence record of max 1024 saved memory of K-PAM F300.

All event record is resolution of 10ms and recorded with occurrence time information, recorded data is managed by way of FIFO(First In, First Out), the recent information is displayed on the first. And the recorded Data is kept permanently even in the case of the Relay control power loss.

Event record category has control power ON/OFF, protection element operation status, input/output contact status, CB control, setting value change, monitoring/diagnostics status, event record delete, fault waveform record delete, power record delete, etc. Protection element operation status event record is recorded with

fault information(voltage/current RMS value and phase).

Event record can see in the field through the LCD and can be checked from local or remote through KBIED_MNE. Displayed event data through LCD is displayed shortened terms, original text and details of shortened terms is as follows.

EVENT DISPLAY CATEGORY		REFERENCE
System Reset	Power ON	Relay Control Power ON
	Power OFF	Relay Control Power OFF
System Error	DC Power	DC Power Error Occurrence
	CPU WatchDog	CPU except Error Occurrence
	Memory	Memory Error Occurrence
	Setting	Setting Error Occurrence
	AD Converter	A/D Converter Error Occurrence
	DO/I Circuit	DO/I Circuit Error Occurrence
DI Change	DI1 Low to High Chg	DI 1 Input Change
	DI1 High to Low Chg	
	DI1 Low to High Chg	DI 2 Input Change
	DI1 High to Low Chg	
CB Control	Local - OPEN	Local - CB Open
	Remote - OPEN	Remote - CB Open
	Local - CLOSE	Local - CB Close
	Remote - CLOSE	Remote - CB Close
	Local Mode	CB control Local Change
	Remote Mode	CB control Remote Change
CB Status	OPEN	State Change by CB Open
	CLOSE	State Change by CB Close
	Trouble	CB status input trouble
PROT Pickup/ Prot Operation/ Release	TOCR (A,B,C)	Time Over-Current A,B,C Phase Pickup/Operation/Return
	IOCR (A,B,C)	Instantaneous Over-Current A,B,C Phase Pickup/Operation/Return
	TOCGR	Time Ground Over-Current Pickup/Operation/Return
	IOCGR	Instantaneous Ground Over-Current Pickup/Operation/Return
	SGR	Select Ground Over-Current Pickup/Operation/Return
	OVR (A,B,C)	Over-Current A,B,C Phase Pickup/Operation/Return
	UVR (A,B,C)	Under-Current A,B,C Phase Pickup/Operation/Return
	TOVGR	Time Ground Over-Current Pickup/Operation/Return
	IOVGR	Instantaneous Ground Over-Current Pickup/Operation/Return
NSOVR	Reverse Phase Over-Voltage Pickup/Operation/Return	

Setting Change	TOCR	TOCR Setting Change
	IOCR	IOCR Setting Change
	TOCGR	TOCGR, TDOCGR Setting Change
	IOCGR	IOCGR, IDOCGR Setting Change
	SGR	SGR Setting Change
	OVR	OVR Setting Change
	UVR	UVR Setting Change
	TOVGR	TOVGR Setting Change
	IOVGR	IOVGR Setting Change
	NSOVR	NSOVR Setting Change
	FREQUENCY	frequency Setting Change
	PT CON	PT CONNECTION Setting Change
	Phase PT Sec	Rated Phase PT Secondary Setting Change
	Phase PT Ratio	Phase PT Ratio Setting Change
	Ground PT Sec	Rated Ground PT Secondary Setting Change
	Ground PT Ratio	Ground PT Ratio Setting Change
	Phase CT Ratio	Phase CT Ratio Setting Change
	Ground CT Ratio	Ground CT Ratio Setting Change
	CB Control	CB Control Setting Change
	T/S Output	T/S Output Setting Change
	Waveform Record	Waveform Setting Change
Communication	Communication Setting Change	
PASSWORD	PASSWORD Setting Change	
System Time	SYSTEM TIME Setting Change	
Annunciator	ProtOP	Protection annunciator reset
Reset	SYSTEM ERROR	System Error annunciator reset
Clear Event		Event Record Clear
Clear Waveform		Fault Waveform Record Clear
Clear Energy		Energy Record Clear
CB OPEN CNT Change		CB Open Count Change
Waveform Capture		Fault Waveform Record Capture
Event ID Error.		Event ID Error Occurrence

3.4.3.2 RECORD ► WAVEFORM

DISPLAY/RECORD/WAVEFORM display all fault waveform record data, Trigger time and content is stored memory of K-PAM F300.

Fault waveform record content is included Trigger Source and simple reference, fault waveform record can record to up to max 6 Block.

Resolution is 32samples per cycle, max record time is 2.8sec per Block and fault waveform record is kept permanently even in the case of the Relay control power loss.

Waveform record include sample data of voltage/current, contact input/output status, protection element operation status, and you can be check from local or remote through KBIED_MNE.

Fault waveform record can be reproduced fault through fault analysis and protection relay tester because of record by COMTRADE File Format.

3.4.3.3 RECORD ► CB OPEN CNT

DISPLAY/RECORD/CB OPEN CNT display CB OPEN Counter stored by memory of K-PAM F300.

3.4.4 Relay Version Display (SYS INFO)

DISPLAY/SYS INFO can be identify the Version information of Relay DSP.



















Version information of DSP is standard when relay update, therefore please check Version information.

4. Setting Description

Setting menu of K-PAM F300 is Clear, TEST screen to display/change, record the setting value required for the function operation of relay

The set value can be checked the front key operation, but if you change the setting value, password must be inputted.

■ Setting by front display control panel

- (1) If you change the setting value, after select the change category using UP() , DOWN() Key, press the RIGHT() Key in detail menu.
- (2) When asked for password, move to each digit using LEFT() , RIGHT() Key, after input password using UP() , DOWN() Key, press the ENTER() Key. **(Password default value is "0000")**
- (3) After you input the correct Password, if you press the RIGHT() Key, flash the setting value. If you input the wrong password, password again asks.
- (4) After select the setting value using the UP() , DOWN() Key, press the ENTER() Key.
- (5) If you press the LEFT() Key before pressing the ENTER() Key, return to the previous setting value.
- (6) If you return to intial screen using LEFT() Key, ask you setting whether to save, after select "YES" using UP() , DOWN() Key, press the ENTER() Key, then you can save the changed setting value
- (7) If you select "NO", set value is canceled. And if you change a various category simultaneously, password does not require to input when SETTING MODE Block does not diverge.
- (8) **You can be easily corrected using KBIED_MNE**

4.1 PROTECTION

SETTING/PROTECTION can be set the protection element of K-PAM F300.

Protection element of relay has short circuit/ground over-current protection(50/51, 50N/51N), direction ground over-current protection(67N), select ground over-current protection(67G), over-voltage protection(59), under-voltage protection(27), ground over-voltage protection(64(59G)), reverse over-voltage protection(47).

■ FUNCTION

All protection element has Function selection setting category, it can be performed protection function.

If Function Selection set to Disabled, the protection function does not operated.

4.1.1 Over-Current Protection (OCR : 50/51)

Over-current protection is composed of Instantaneous time/Definite time short circuit over-current protection(50), Time short circuit over-current protection(51).

Minimum operating time of Instantaneous time/Definite time element is less than 40msec(When setting value of 2times is input), Inverse time element characteristic curve consist of IEC 4types, KEPCO 4 types.

Inverse Time characteristic is a function of current over time, and when the current gets bigger, the operation time shortens, and the operational characteristics are set as the same as an induction type Relay, so it is convenient that you can set the same when an induction type Relay is used as an alternative.

Also, in the Inverse Time characteristic, it operates the same time of 2000% input when more than 2000% current is input than the setting value of the Relay.

Detected current of over-current protection use CT secondary side current.

The time and current relative equation of Inverse time characteristic is as follows.

$$T = \left(\frac{K}{\left(\frac{I}{I_s}\right)^L - 1} + C \right) \times \frac{M}{10} (\text{sec})$$

In this, T: operation time, K and C: relay characteristic value, I: relay input current
 I_s : Relay operation setting value, L: characteristic curve index, M: operation time lever(Time Multiplier)

CURVE	Symbol	K	L	C
IEC Normal Inverse	NI	0.14	0.02	0.00
IEC Very Inverse	VI	13.50	1.00	0.00
IEC Extremely Inverse	EI	80.00	2.00	0.00
IEC Long Inverse	LI	120.00	1.00	0.00
KEPCO Normal Inverse	KNI	0.11	0.02	0.42
KEPCO Very Inverse	KVI	39.85	1.95	1.08
KEPCO Long Normal Inverse	KLNI	3.8	0.11	2.8
KEPCO Long Very Inverse	KLVI	75	1.8	2

If you select inverse time characteristics curve when setting the Relay, the values of K, L, and C are decided on the above table.

Detail information on the characteristic curve is please refer to [Appended.1 characteristic curve](#)

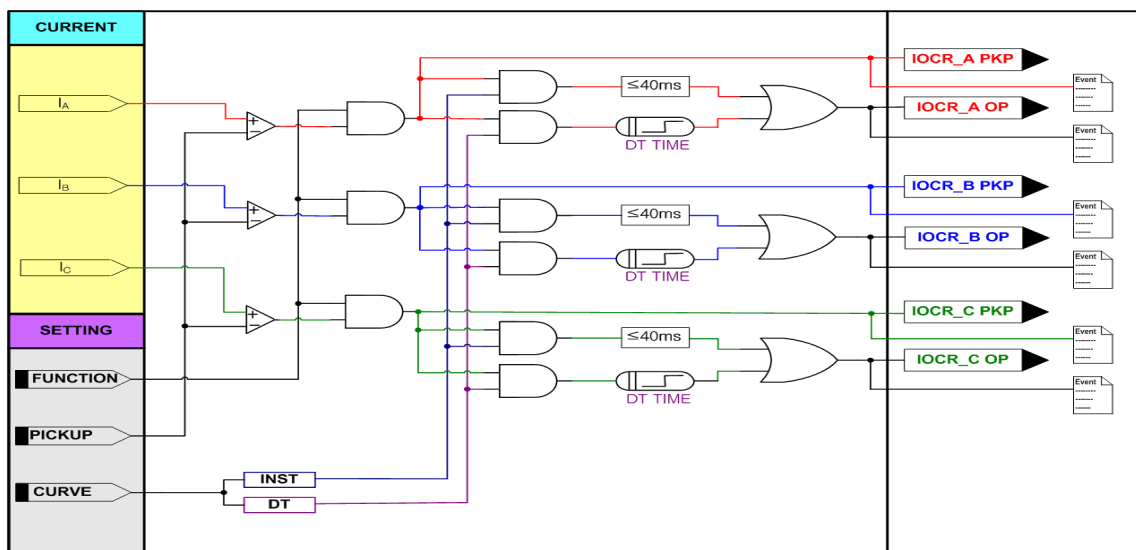

<Figure 6. Instantaneous/Definite Time Over-Current Protection Operation Characteristic>

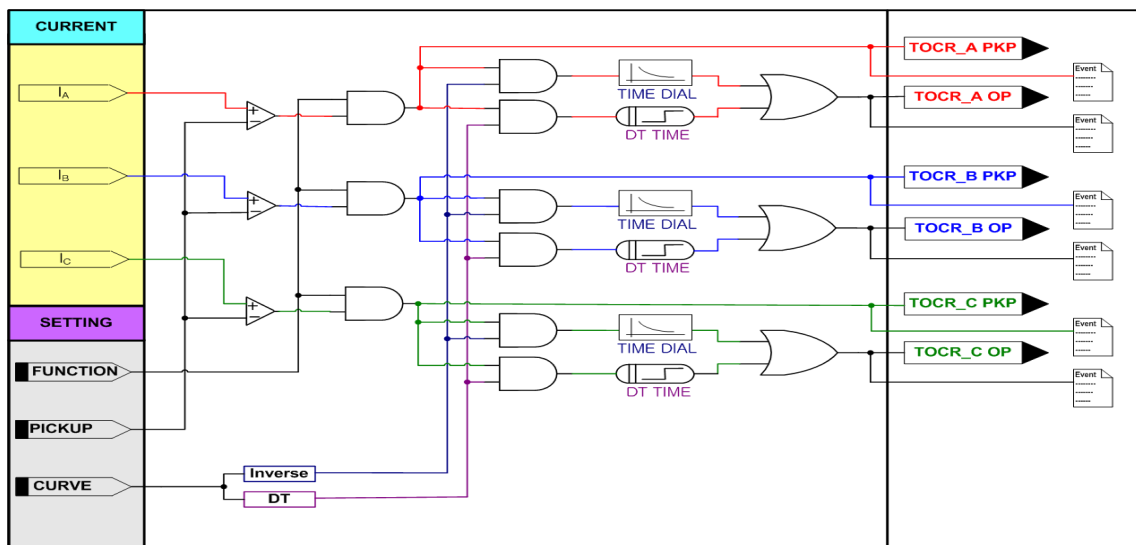

< Figure 7. Time Over-Current Protection Operation Characteristic >

Setting Category	Step	Unit	Reference
1. FUNCTION	ENABLE, DISABLE		Use or Not Use
2. CURVE	DT, INST		Definite, Instantaneous Setting
3. PICKUP	0.1 ~ 100.0 (0.5)	A	Pickup Current Setting
4. DT TIME	0.04 ~ 60.00 (0.01)	sec	Definite Time Operation Time Setting

<Table 1. IOCR(50) Setting Menu>

Setting Category	Step	Unit	Reference
1. FUNCTION	ENABLE, DISABLE		Use or Not Use
2. CURVE	NI, ... , KLVI, DT		Inverse Time Characteristic Curve Setting NI : IEC Normal Inverse VI : IEC Very Inverse EI : IEC Extremely Inverse LI : IEC Long Inverse KNI : KEPCO Normal Inverse KVI : KEPCO Very Inverse KLNI : KEPCO Long Normal Inverse KLVI : KEPCO Long Very Inverse DT : Definite Time
3. PICKUP	0.2 ~ 16.0 (0.1)	A	Pickup Current Setting
4.	TIME DIAL	0.05 ~ 10.00 (0.05)	Time Multiplier Setting
	DT TIME	0.04 ~ 60.00 (0.01)	sec Definite Time Operation Time Setting

<Table 2. TOCR(51) Setting Menu>

4.1.2 OCGR : 50/51N, DOCGR : 67N

OCGR is composed of Instantaneous/Definite time ground over-current protection(50N), time ground over-current protection(51N), direction ground over-current protection(67N).

Minimum operating time of Instantaneous time/Definite time element is less than 40msec(When setting value of 2times is input), Inverse time element characteristic curve consist of IEC 4types, KEPCO 4 types.

Inverse Time characteristic is a function of current over time, and when the current gets bigger, the operation time shortens, and the characteristic curve of KEPCO 4 type are set as the same as an induction type Relay, so it is convenient that you can set the same when an induction type Relay is used as an alternative.

Also, in the Inverse Time characteristic, it operates the same time of 2000% input when more than 2000% current is input than the setting value of the Relay.

Ground directional detection element is applied determine the direction of current flow from normal status or fault status of ground system.

Ground directional detection element(67N) determine to direction by comparing the size and phase of voltage phase(VN), ground current(IN).

Ground over-current and direction ground over-current has direction setting(DIR), if DIR set to "DISABLE", operate as ground over current, if DIR set to "ENABLE", operate as direction ground over-current.

Input current of ground over-current protection element can be obtained from CT for ground protection or residual connection of 3 phase CT.

The voltage used for direction ground over-current inputted from abandoned voltage of GPT tertiary side.

The time and current relative equation of Inverse time characteristic is as follows.

$$T = \left(\frac{K}{\left(\frac{I}{I_s}\right)^L - 1} + C \right) \times \frac{M}{10} (\text{sec})$$

In this, T: operation time, K and C: relay characteristic value, I: relay input current
 I_s : Relay operation setting value, L: characteristic curve index, M: operation time lever(Time Multiplier)

CURVE	Symbol	K	L	C
IEC Normal Inverse	NI	0.14	0.02	0.00
IEC Very Inverse	VI	13.50	1.00	0.00
IEC Extremely Inverse	EI	80.00	2.00	0.00
IEC Long Inverse	LI	120.00	1.00	0.00
KEPCO Normal Inverse	KNI	0.11	0.02	0.42
KEPCO Very Inverse	KVI	39.85	1.95	1.08
KEPCO Long Normal Inverse	KLNI	3.8	0.11	2.8
KEPCO Long Very Inverse	KLVI	75	1.8	2

When you select inverse time characteristics curve when setting the Relay, the values of K, L, and C are decided on the above table.

Detail information on the characteristic curve is please refer to **Appended.1 characteristic curve**

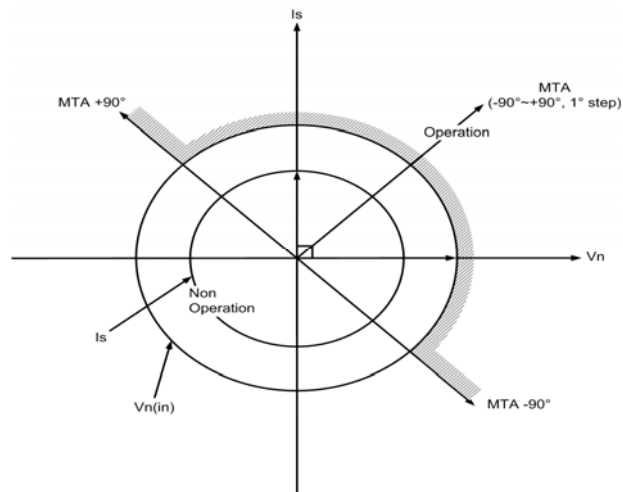

< Figure 8. Ground fault direction detection direction characteristic >

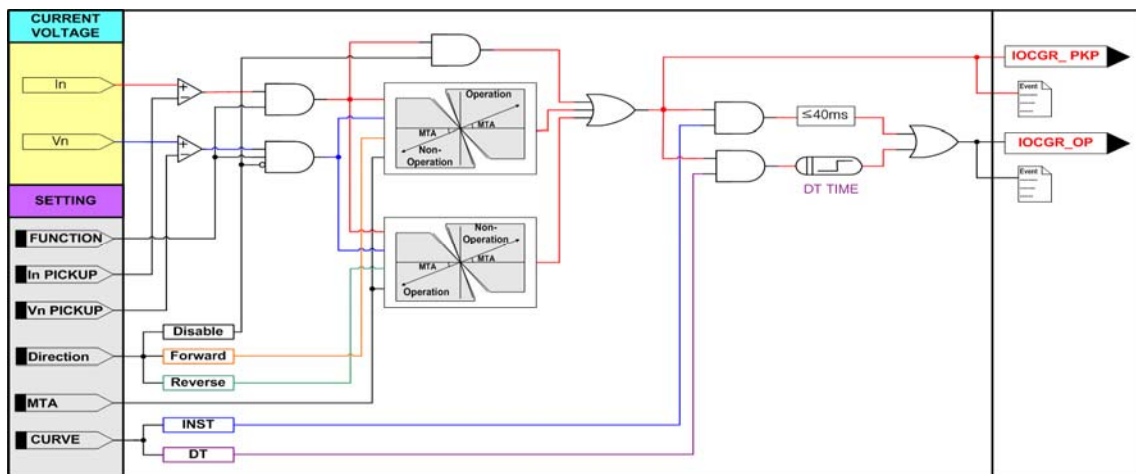

< Figure 9. (Direction) Instantaneous/Definite Time Ground Over-Current Protection

Operation Characteristic >

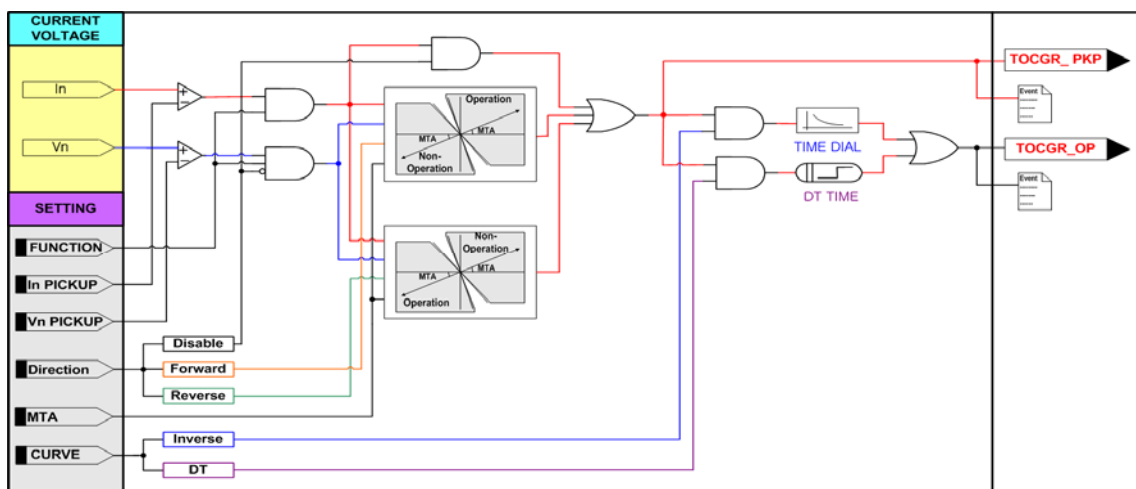

< Figure 10. (Direction) Time ground over current protection operation characteristic >

Setting Category	Step	unit	Reference
1. FUNCTION	ENABLE, DISABLE		Use or Not use
2. CURVE	DT, INST		Definite Time, Instantaneous Setting
3. DIR	DISABLE, FORWARD, REVERSE		DISABLE : Ground Over-Current FORWARD : Forward directional ground over-current REVERSE : Reverse directional ground over-current
4. IN PICKUP	0.5 ~ 50.0 (0.1)	A	Pickup Current Setting
5. VN PICKUP	5 ~ 170V (1)	V	Pickup Voltage Setting
6. DT TIME	0.04 ~ 60.00 (0.01)	sec	Definite Time Operation Time Setting
7. MTA	-90 ~ 90 (1)	°	MTA Setting

< Table 3. IOCGR(50N), IDOCGR(67N) Setting Menu >

Setting Category	Step	unit	Reference
1. FUNCTION	ENABLE, DISABLE		Use or Not use
2. CURVE	NI, ... , KLVI, DT		Inverse Time Characteristic Curve Setting NI : IEC Normal Inverse VI : IEC Very Inverse EI : IEC Extremely Inverse LI : IEC Long Inverse KNI : KEPCO Normal Inverse KVI : KEPCO Very Inverse KLNI : KEPCO Long Normal Inverse KLVI : KEPCO Long Very Inverse DT : Definite Time
3. DIR	DISABLE, FORWARD, REVERSE		DISABLE : Ground Over-Current FORWARD : Forward directional ground over-current REVERSE : Reverse directional ground over-current
4. IN PICKUP	0.1 ~ 10.0 (0.1)	A	Pickup Current Setting
5. VN PICKUP	5 ~ 170V (1)	V	Pickup Voltage Setting
6. TIME DIAL	0.05 ~ 10.00 (0.05)		Time Multiplier Setting
7. DT TIME	0.04 ~ 60.00 (0.01)	sec	Definite Time Operation Time Setting
8. MTA	-90 ~ 90 (1)	°	MTA Setting

< Table 4. TOCGR(51N), TDOCGR(67N) Setting Menu >

4.1.3 Select Ground Over-Current Protection (SGR : 67G)

Select ground over-current element is direction protection element used by ground fault detection of non-grounded system and operate by size/phase of zero sequence voltage and zero sequence current.

In non-grounded system, current circuit be formed through leakage capacitance components between the earth and the line, therefore fault current is very small.

To detect the small fault current use the good sensitivity ZCT for zero sequence current of small current area, zero sequence voltage element is used simultaneously to fault direction determine whether self protection sector.

Direction setting of K-PAM F300 is “FORWARD”, “REVERSE”, “**DISABLED**”, when set to “**DISABLED**”, operate to size of zero sequence current regardless of size and phase of zero sequence voltage.

Inverse Time characteristic is a function of current over time, and when the current gets bigger, the operation time shortens, and the inverse characteristic curve are set as the same as an induction type Relay, so it is convenient that you can set the same when an induction type Relay is used as an alternative.

Also, in the Inverse Time characteristic, it operates the same time of 2000% input when more than 2000% current is input than the setting value of the Relay.

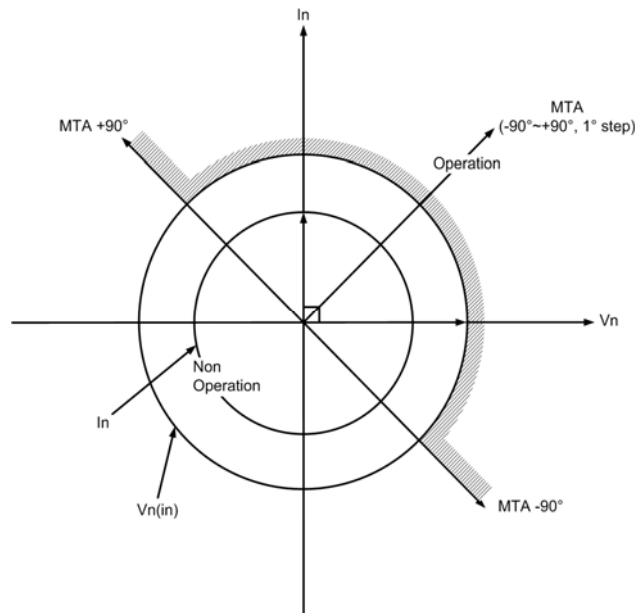

< Figure 11. Select Ground Over Current Protection Operation Angle Characteristic >

Directional operation phase of select ground over-current protection element is as follows.

Operation area : $\cosine (\angle -3V0(VG) + MTA - \angle Is) \geq 0$

Non operation area : $\cosine (\angle -3V0(VG) + MTA - \angle Is) < 0$

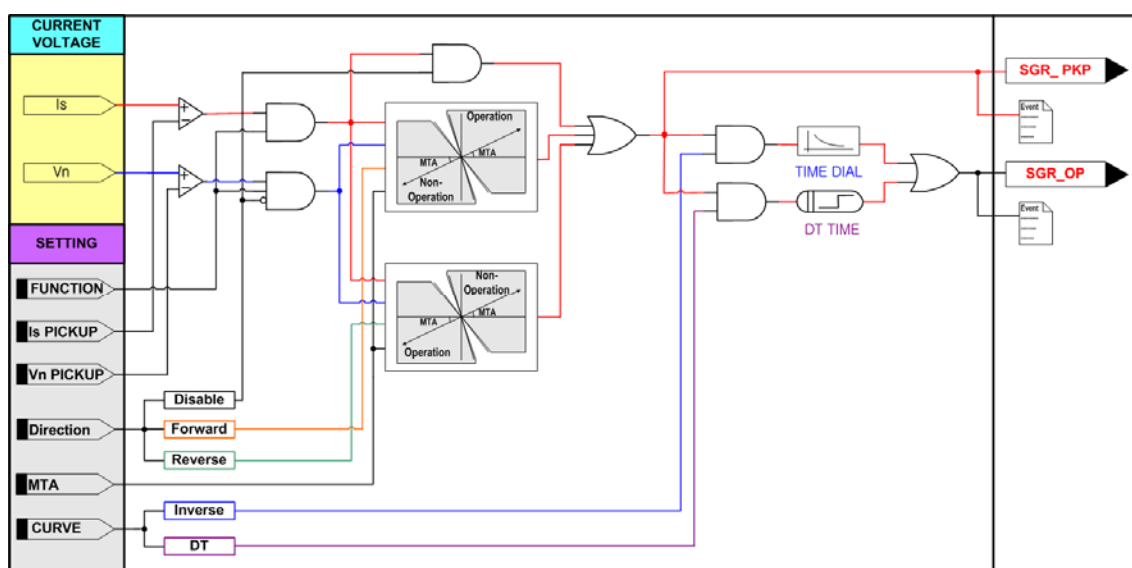

< Figure 12. Select Ground Over Current Protection Operation Characteristic >

Setting Category	Step	Unit	Reference
1. FUNCTION	ENABLE, DISABLE		Use or Not use
2. CURVE	DT, NI		Definite Time, Inverse Time Setting
3. DIR	DISABLE, FORWARD, REVERSE		DISABLE : Ground Over-Current FORWARD : Forward directional ground over-current REVERSE : Reverse directional ground over-current
4. IS PICKUP	0.9 ~ 250 (0.1)	mA	Pickup Current
5.	TIME DIAL	0.05 ~ 10.00 (0.05)	Time Multiplier Setting
	DT TIME	0.04 ~ 60.00 (0.01)	sec Definite Time Operation Time Setting
6. VN PICKUP	5 ~ 170 (1)	V	Pickup Voltage
7. MTA	-90 ~ 90 (1)	°	MTA Setting

< Table 5. SGR(67G) Setting Menu >

4.1.4 Over-Voltage Protection (OVR : 59)

Over-voltage protection element is 3phase protection element operated as definite time/inverse time element.

Inverse Time characteristic is a function of voltage and time, and when the voltage gets bigger, the operation time shortens, and the operation characteristic are set as the same as an induction type Relay, so it is convenient that you can set the same when an induction type Relay is used as an alternative.

Also, in the Inverse Time characteristic, it operates the same time of 250% input

when more than 250% voltage is input than the setting value of the Relay.

Detail information on the characteristic curve is please refer to **Appended.1 characteristic curve**

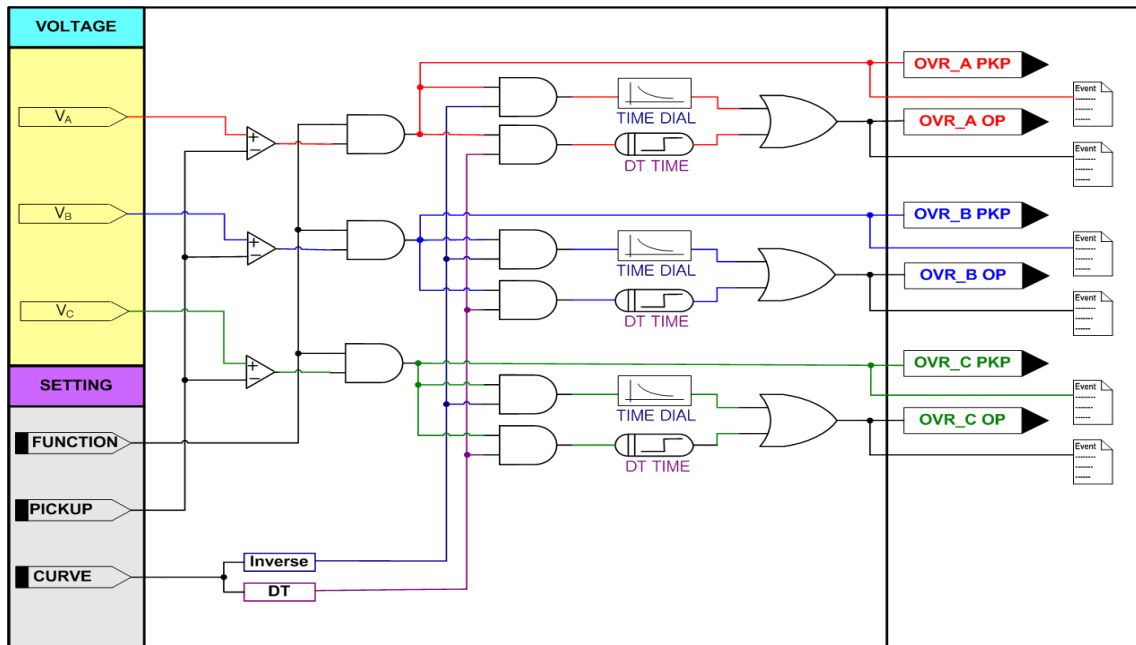

< Figure 13. Over-Voltage Protection Operation Characteristic >

Setting Category	Step	Unit	Reference
1. FUNCTION	ENABLE, DISABLE		Use or Not use
2. CURVE	DT, NI		Definite Time, Invers Time Setting
3. PICKUP	5 ~ 170 (1)	V	Voltage Pickup Setting
4.	TIME DIAL	0.05 ~ 10.00 (0.05)	Time Multiplier Setting
	DT TIME	0.04 ~ 60.00 (0.01)	sec Definite Time Operation Time Setting

< Table 6. OVR(59) Setting Menu >

4.1.5 Under-Voltage Protection (UVR : 27)

Under-voltage protection element is 3phase under-voltage protection element operated as definite time/reverse inverse time element.

Reverse inverse Time characteristic is a function of voltage and time, and when the voltage gets smaller, the operation time shortens, and OP MODE can be set to DIGITAL and INDUCTION mode. When it is set to DIGITAL, the Undervoltage element does not operate when the initial power is supplied to the relay or after Reset recovery, and it only operates when the voltage goes above the setting value and drops under the setting value. When it is set to INDUCTION, it maintains the induction type relay operation characteristic, so the existing induction type relays are generally acceptable.

Detail information on the characteristic curve is please refer to **Appended.1 characteristic curve**

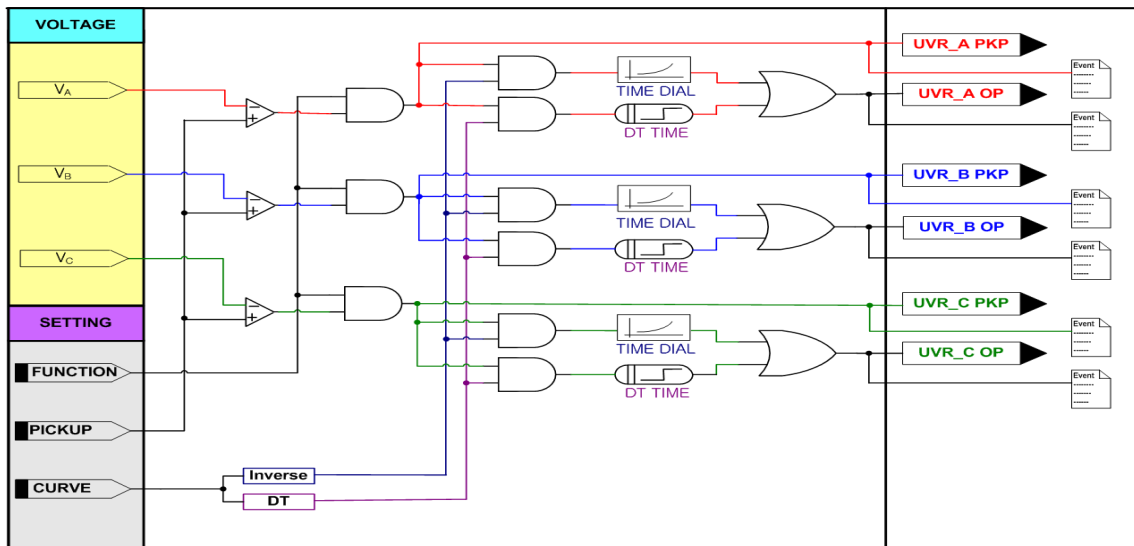

<Figure 14. Under-Voltage Protection Operation Characteristic>

Setting Category	Step	Unit	Reference
1. FUNCTION	ENABLE, DISABLE		Use or Not use
2. CURVE	DT, NI		Definite Time, Reverse Inverse Time Setting
3. PICKUP	5 ~ 170 (1)	V	Voltage Pickup Setting
4.	TIME DIAL	0.05 ~ 10.00 (0.05)	Time Multiplier Setting
	DT TIME	0.04 ~ 60.00 (0.01)	sec Definite Time Operation Time Setting
5. OP_MODE	DIGITAL, INDUCTION		Operation mode setting

< Table 7. UVR(27) Setting Menu >

4.1.6 Ground Over-Voltage Protection (OVGR : 64(59G))

Ground over-voltage protection element is single phase protection element consist of IOVGR operated as instantaneous time/definite time element and TOVGR operated as definite time/inverse time element.

Ground over-voltage protection element can protect ground fault when system ground fault. When ground fault, occurred zero sequence voltage is inputted through GPT(Ground PT).

Inverse Time characteristic of ground over-voltage protection element is a function of voltage and time, and when the voltage gets bigger, the operation time shortens, and the operation characteristic are set as the same as an induction type Relay, so it is convenient that you can set the same when an induction type Relay is used as an alternative.

Also, in the Inverse Time characteristic, it operates the same time of 1000% input when more than 1000% voltage is input than the setting value of the Relay.

Minimum operation time of Instantaneous time/Definite time element is 40msec or less.

Detail information on the characteristic curve is please refer to [Appended.1 characteristic curve](#)

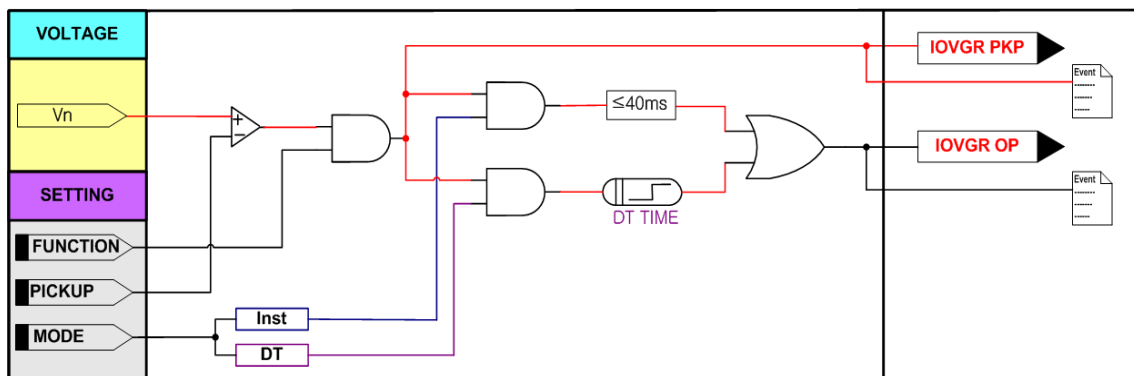

< Figure 15. Instantaneous/Definite Time Ground Over-Voltage Protection Operation Characteristic >

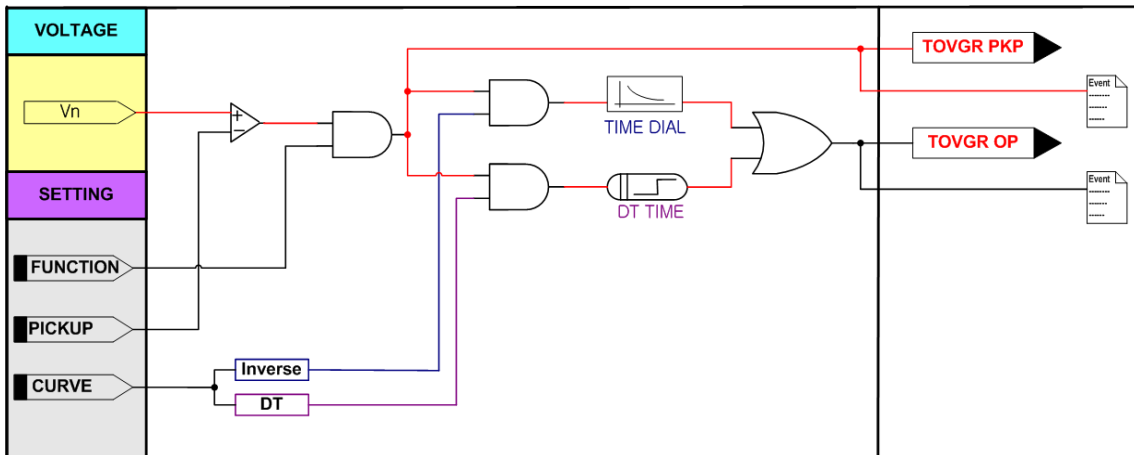

< Figure 16. Time Ground Over-Voltage Protection Operation Characteristic >

Setting Category	Step	Unit	Reference
1. FUNCTION	ENABLE, DISABLE		Use or Not use
2. CURVE	DT, INST		Definite Time, Instantaneous Setting
3. PICKUP	10 ~ 170 (1)	V	Voltage Pickup Setting
4. DT TIME	0.04 ~ 60.00 (0.01)	sec	Operation Time Delay Setting

< Table 8. IOVGR (64(59G)) Setting Menu >

Setting Category	Step	Unit	Reference
1. FUNCTION	ENABLE, DISABLE		Use or Not use
2. CURVE	DT, NI_TRIP, NI_ALARM		DT : Definite Time NI_TRIP : Inverse Time for Trip NI_ALARM : Inverse Time for Alarm
3. PICKUP	5 ~ 170 (1)	V	Voltage Pickup Setting
4.	TIME DIAL	0.05 ~ 10.00 (0.05)	Time Multiplier Setting
	DT TIME	0.04 ~ 60.00 (0.01)	sec Definite Time Operation Time Setting

< Table 9. TOVGR (64(59G)) Setting Menu >

4.1.7 Reverse Phase Over-Voltage Protection (NSOVR : 47)

Reverse phase over-voltage protection element is definite time protection element operated by size of reverse phase voltage. The reverse phase voltage(V2) used for reverse phase over-voltage protection is

$$V2 = \frac{1}{3}(\dot{V}_A + a^2 \dot{V}_B + a \dot{V}_C), \text{ ABC phase rotation.}$$

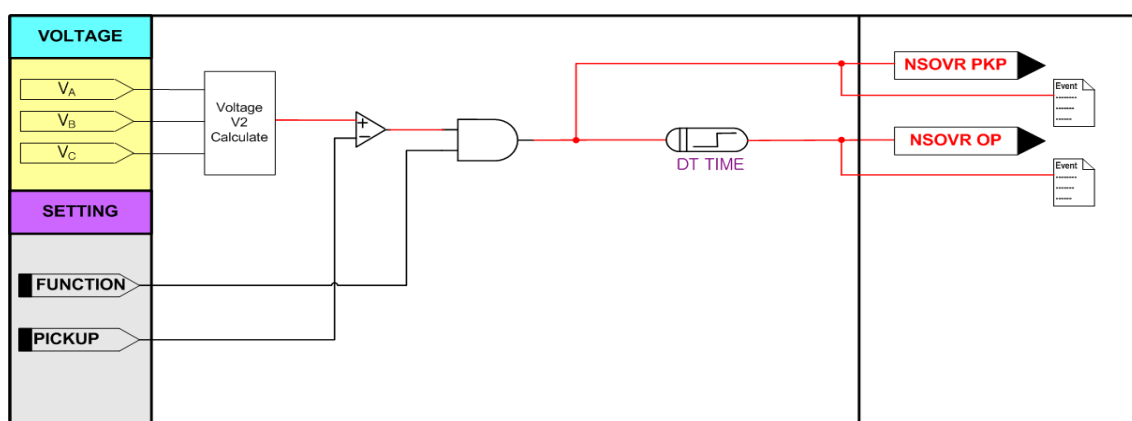

<Figure 17. Reverse Phase Over-Voltage Protection Operation Characteristic>

Setting Category	Step	Unit	Reference
1. FUNCTION	ENABLE, DISABLE		Use or Not use
2. PICKUP	5 ~ 170 (1)	V	Reverse Phase Voltage Pickup Setting
3. DT TIME	0.04 ~ 60.00 (0.01)	sec	Operation Time Delay Setting

<Table 10. NSOVR (47) Setting Menu>

4.2 SYSTEM

SYSTEM setting category of K-PAM F300 has Power System, Circuit Breaker, T/S Output, System Time, Fault Waveform, Communication and Password.

4.2.1 POWER SYSTEM

SETTING/SYSTEM/POWER SYSTEM has POWER SYSTEM for analog circuit configuration setting.

4.2.1.1 POWER SYSTEM ► FREQUENCY

Rated frequency is important element used measurement and protection calculation of K-PAM F300. Therefore should be set according to the frequency of system.

If the set frequency is different from the system frequency, measurement oscillate violently and cause operation characteristic of protection element error.

Rated frequency can be set through Key pad of relay or KBIED_MNE.

4.2.1.2 POWER SYSTEM ► PT CONNECT

PT connection is important element used measurement and protection calculation, therefore should be set for system.

If set connection method is different from local connection, measurement value is different and cause malfunction of protection element.

If PT connection is "NONE", phase voltage and line-line voltage measurement display as "0 V", if PT connection is "DEL", phase voltage measurement display as "0 V" and if 3 phase voltage does not input, 3 phase power display as "0".

Connection can be set through Key pad of relay or KBIED_MNE.

4.2.1.3 POWER SYSTEM ▶ PT Ratio

K-PAM F300 has 4 voltage input. This voltage is voltage input of all protection element used voltage.

Phase/Ground voltage ratio setting can be set through Key pad of relay or KBIED_MNE.

▶ Measurement Display Screen Phase/line-line Voltage Value

= Phase PT RATIO×Input Voltage(V)

▶ Measurement Display Screen Ground Voltage Value

= Ground PT RATIO×Input Voltage(V)

4.2.1.4 POWER SYSTEM ▶ PT SEC

It is a category to set the PT secondary rating of phase voltage or zero sequence voltage entered into relay, it does not affect the protection element but only give a information of phase PT secondary rating from waveform record.

Phase/Ground rated voltage setting can be set through Key pad of relay or KBIED_MNE.

4.2.1.5 POWER SYSTEM ▶ CT Ratio

K-PAM F300 has 4 current input. This current is current source of all protection element used current.

Phase/Ground current ratio setting can be set through Key pad of relay or KBIED_MNE.

▶ Measurement Display Screen Phase Current value

= Phase CT RATIO×Input Current(A)

▶ Measurement Display Screen Ground Current value

= Ground CT RATIO×Input Current(A)

Setting Category	Step	Unit	Reference
1. FREQUENCY	60Hz, 50Hz		Rated Frequency Setting
2. PT CONNECT	NONE, WYE, DELTA		PT Wiring Setting
3. Phase PT SEC	50.0 ~ 240.0 (0.1)	V	Rated Phase PT Secondary Setting
4. Phase PT RATIO	0.1 ~ 6500.0 (0.1)		Phase PT Ratio Setting
5. Ground PT SEC	50.0 ~ 240.0 (0.1)	V	Rated Ground PT Secondary Setting
6. Ground PT RATIO	0.1 ~ 6500.0 (0.1)		Ground PT Ratio Setting
7. Phase CT RATIO	5 ~ 3000 : 5		Phase CT Ratio Setting
8. Ground CT RATIO	5 ~ 3000 : 5		Ground CT Ratio Setting

< Table 11. POWER SYSTEM SETTING MENU >

4.2.2 CB CONTROL

SETTING/SYSTEM/CB Control can set for control of Circuit Breaker.

CB status is receiving a contact input 52a and 52b, display CB status according to 2 contact input status. If 2 contact status is equal, judged that there is problem in the Circuit Breaker, you can not control the circuit breaker.

If CB status display an abnormally, please check the connect status.

Setting Category	Step	Unit	Reference
1. FUNCTION	ENABLE, DISABLE		Use or Not use
2. KEY CTRL	ENABLE, DISABLE		CB Local control permission or not permission DISABLED : CB can not be controled in local
3. OPEN TIME	0.1 ~ 5.0 (0.1)	sec	CB OPEN Control Output Time
4. CLOSE TIME	0.1 ~ 5.0 (0.1)	sec	CB CLOSE Control Output Time
5. CB INPUT	52a+52b, 52a, 52b		Select Input Method

< Table 12. CB CONTROL Setting Menu >

4.2.3 T/S OUTPUT

SETTING/SYSTEM/T/S OUTPUT can set each for control of 10 output contacts.

Contact output condition and restoration method for output contacts, and restoration delay time for output contacts can be set.

4.2.3.1 T/S OUTPUT ► CONNECTION

It is a category to set on which conditions to operate the output contacts.



If you set to DISABLE, the output contacts are not used.

"SYS_ERR" among the output contacts conditions is a condition to operate when there is a fault in the Relay, and when there is no fault in the Relay, it converts to the opposite contact from the original contact.

That is, if "SYS_ERR" is set on a contact, it stays as b contact, and when a fault occurs in the Relay, it changes to a contact.

4.2.3.2 T/S OUTPUT ► RESET Setting

It is a category to set the restoration methods of output contacts. There are "Self Mode" and "Manual Mode" in the methods of restoration of output contacts.

"Self Mode" is a method that output contacts are automatically restored when the Relay elements are restored, and "Manual Mode" is a method that output contacts are not automatically restored when the Relay elements are restored but is restored when "RESET"()key is pressed, and it maintains the output contacts until "RESET"()key is pressed.

4.2.3.3 T/S OUTPUT ► DELAY Setting

It is a category to delay the restoration time of output contacts.

This menu only applies to when it is set to "Self Mode", and it is not set in the case of "Manual Mode".

Setng Category	Step	Reference
1. Connection	OFF	Not Use
	CB_OPEN	CB Open Control
	CB_CLOSE	CB Close Control
	ALL_PROT	All Protection element Operation OR
	OCR	Over-Current Protection Operation OR
	TOC	Time Over-Current Protection Operation OR
	IOC	Instantaneous Over-Current Protection Operation OR
	OC_A	Over-Current A Phase Operation
	OC_B	Over-Current B Phase Operation
	OC_C	Over-Current C Phase Operation
	TOC_A	Time Over-Current A Phase Operation
	TOC_B	Time Over-Current B Phase Operation
	TOC_C	Time Over-Current C Phase Operation
	IOC_A	Instantaneous Over-Current A Phase Operation
	IOC_B	Instantaneous Over-Current B Phase Operation
IOC_C	Instantaneous Over-Current C Phase Operation	

Setting Category	Step	Reference
1. Connection	OCGR	Ground Over-Current Protection Operation OR
	TOCG	Time Ground Over-Current Protection Operation
	IOCG	Instantaneous Ground Over-Current Protection Operation
	SGR	Select Ground Over-Current Protection Operation
	OVR	Over-Voltage Protection Operation OR
	OV_A	Over-Voltage A Phase Operation
	OV_B	Over-Voltage B Phase Operation
	OV_C	Over-Voltage C Phase Operation
	UVR	Under-Voltage Protection Operation OR
	UV_A	Under-Voltage A Phase Operation
	UV_B	Under-Voltage B Phase Operation
	UV_C	Under-Voltage C Phase Operation
	OVGR	Ground Over-Voltage Protection Operation OR
	TOVG	Time Ground Over-Voltage Protection Operation
	IOVG	Instantaneous Ground Over-Voltage Protection Operation
	NSOVR	Negative Sequence Over-Voltage Protection Operation
	OC+OCG	Over-Current + Ground Over-Current Protection Operation
	TOC+TOCG	Time Over-Current + Time Ground Over-Current Protection Operation
	IOC+IOCG	Instantaneous Over-Current + Instantaneous Ground Over-Current Protection Operation
	OC+SG	Over-Current + Select Ground Over-Current Protection Operation
	OC+OV	Over-Current + Over-Voltage Protection Operation
OC+UV	Over-Current + Under-Voltage Protection Operation	
OC+OVG	Over-Current + Ground Over-Voltage Protection Operation	
OC+NSOV	Over-Current + Negative Sequence Over-Voltage Protection Operation	
OCG+SG	Ground Over-Current + Select Ground Over-Current Protection Operation	

Setting Category	Step	Reference
1. Connection	OCG+OV	Ground Over-Current + Over-Voltage Protection Operation
	OCG+UV	Ground Over-Current + under-Voltage Protection Operation
	OCG+OVG	Ground Over-Current + Gound Over-Voltage Protection Operation
	OCG+NSOV	Ground Over-Current + Negative Sequence Over-Voltage Protection Operation
	SG+OV	Select Ground Over-Current + Over-Voltage Protection Operation
	SG+UV	Select Ground Over-Current + Under-Voltage Protection Operation
	SG+OVG	Select Ground Over-Current + Gound Over-Voltage Protection Operation
	SG+NSOV	Select Ground Over-Current + Negative Sequence Over-Voltage Protection Operation
	OV+UV	Over-Voltage + Under-Voltage Protection Operation
	OV+OVG	Over-Voltage + Gound Over-Voltage Protection Operation
	OV+NSOV	Over-Voltage + Negative Sequence Over-Voltage Protection Operation
	UV+OVG	Under-Voltage + Gound Over-Voltage Protection Operation
	UV+NSOV	Under-Voltage + Negative Sequence Over-Voltage Protection Operation
OVG+NSOV	Gound Over-Voltage + Negative Sequence Over-Voltage Protection Operation	
2. RESET	SYS_ERR	Self Diagnosis Operation
	SELF, MANUAL	Contact Return Method Setting
3. DELAY	0.0 ~ 200.0 (0.01)sec	Release Delay Time

< Table 13. T/S OUTPUT Setting Menu >

4.2.4 SYSTEM TIME

SETTING/SYSTEM/SYSTEM TIME used to change the time of protection relay. Setting procedure is year/month/day/hour/minute/second.

When change the RTC time, go to the RTC menu, select category using RIGHT(▶) Key LEFT(◀) Key. And change the time value using UP(▲), DOWN(▼) Key next press the ENTER(ENT) Key, then relay set to changed time.

Setting Category	Step	Reference
YYYY	2000 ~ 2100 (1)	Year Setting
MM	01 ~ 12 (1)	Month Setting
DD	01 ~ 31 (1)	Day Setting
HH	00 ~ 23 (1)	Hour Setting
MM	00 ~ 59 (1)	Minute Setting
SS	00 ~ 59 (1)	Second Setting

<Table 14. RTC Setting Menu>

4.2.5 WAVEFORM RECORD

SETTING/SYSTEM/WAVEFORM RECORD is used to set record to fault waveform. Waveform can be record to max 6 block.

Resolution is 32Sample per 1 cycle, Block Max record time is 2.8sec.

Waveform record is included current/voltage, contacts input/output status, sample data of protection element operation status.

Trigger condition of waveform record is possible to PICKUP of protection element, operation, PICKUP+operation. Trigger position of waveform record can be set to 0 ~ 99% of total Block size.

It has a In/Is setting category, when fault record is set to "In", fault record data record to In current, when fault record is set to "Is", record to ZCT secondary current.

Waveform record can upload from local or remote through KBIED_MNE.

The data can be preserved even the loss of control power of relay, waveform record can be used fault reproduction through fault analysis and protection relay tester.

Setting Category	Step	Unit	Reference
1. TRIGGER POS	0 ~ 99% (1)	Cycle	Trigger Location Setting 40% : Trigger Before Waveform (40%)+ Trigger After Waveform (60%)
2. TRIGGER SRC	OP, PKP, OP+PKP		Trigger Source Setting
3. In / Is	In, Is		Fault Data Setting

< Table 15. WAVEFORM RECORD Setting Menu >

4.2.6 COMMUNICATION

SETTING/SYSTEM/COMMUNICATION can be set the RS-485C communication located relay rear and protocol is embedded ModBus protocol.

Setting Category	Step	Unit	Reference
1. PROTOCOL	ModBus		Application Communication Protocol
2. SLAVE ADDR	1 ~ 254 (1)		Slave Address
3. BPS	300, 1200, 2400, 4800 9600, 19200	BPS	Bit / sec

< Table 16. COMMUNICATION Setting Menu >

4.2.7 PASSWORD

The password is used in K-PAM F300 has setting password(SET PASS) and control password(CTRL PASS).

Setting Password(SET PASS) is used when setting change, control password(CTRL PASS) is used when CB control through KeyPad.

When the product is shipped, Password is set to “0000”, and the both two Password can be changed to 4 digits using digits 0~9.



If you forget the new password, you can not control and change the setting.

4.3 RECORD CLEAR FUNCTION CONTROL













RECORD CLEAR MENU of K-PAM F300 has power delete, event data delete, fault waveform delete, CB OPEN CNT change, etc.

4.3.1 CLEAR EVENT

SETTING/RECORD CLEAR/CLEAR EVENT is menu to clear the Event Data saved in relay.

When you perform a Clear Event, Event and Data both are initialized.

■ Event Data Delete Method







- (1) After in RECORD CLEAR menu screen search to CLEAR EVENT, press the RIGHT() Key.
- (2) If asking the Password, move each digit using LEFT() , RIGHT() Key, input password and press the ENTER() Key using UP() , DOWN() Key.
- (3) After input correct password, when pressing the RIGHT() Key, display the information to be deleted and "NO" flashes. At this time, if you do not want to delete, out of the menu, pressing the LEFT() Key or when "NO" flashes, pressing the ENTER() Key.
- (4) Using UP() , DOWN() Key, "YES" flashes and press the ENTER() Key.
- (5) After the phrase was written as "Event Cleared", switched to CLEAR EVENT menu screen, and Event Data is Clear.

4.3.2 CLEAR WAVEFORM

SETTING/RECORD CLEAR/CLEAR WAVEFORM is menu to clear the fault waveform record saved in relay.

When you perform a Clear Waveform, Fault waveform Data is all initialized.

■ Fault Waveform Record Delete Method

- (1) After in RECORD CLEAR menu screen search to CLEAR WAVEFORM, press the RIGHT() Key.
- (2) If asking the Password, move each digit using LEFT() , RIGHT() Key, input password and press the ENTER() Key using UP() , DOWN()

Key.

- (3) After input correct password, when pressing the RIGHT(▶) Key, display the information to be deleted and "NO" flashes. At this time, if you do not want to delete, out of the menu, pressing the LEFT(◀) Key or when "NO" flashes, pressing the ENTER(ENT) Key.
- (4) Using UP(▲), DOWN(▼) Key, "YES" flashes and press the ENTER(ENT) Key.
- (5) After the phrase was written as "Event Cleared", switched to CLEAR EVENT menu screen, and Event Data is Clear.

4.3.3 CLEAR ENERGY

SETTING/RECORD CLEAR/CLEAR ENERGY is menu to clear the energy data saved in relay.

When you perform a Clear ENERGY, ENERGY Data is all initialized.

■ ENERGY Delete Method















- (1) After in RECORD CLEAR menu screen search to CLEAR ENERGY, press the RIGHT(▶) Key.
- (2) If asking the Password, move each digit using LEFT(◀), RIGHT(▶) Key, input password and press the ENTER(ENT) Key using UP(▲), DOWN(▼) Key.
- (3) After input correct password, when pressing the RIGHT(▶) Key, display the information to be deleted and "NO" flashes. At this time, if you do not want to delete, out of the menu, pressing the LEFT(◀) Key or when "NO" flashes, pressing the ENTER(ENT) Key.
- (4) Using UP(▲), DOWN(▼) Key, "YES" flashes and press the ENTER(ENT) Key.
- (5) After the phrase was written as "Energy Cleared", switched to CLEAR ENERGY menu screen, and Energy Data is Clear.

4.3.4 SET CB OPEN COUNTER

SETTING/RECORD CLEAR/SET CB OPNE CNT is a menu to change the OPEN Counter of CB.

When relay exclusive replacement, relay should be set to CB operating time before replacement for CB management.

■ CB OPEN COUNTER SET Change Method

- (1) After in RECORD CLEAR menu screen search to SET CB OPNE CNT, press the RIGHT() Key.
- (2) In CB OPEN COUNTER setting screen, select the CB using UP() , DOWN() Key and press the RIGHT() Key.
- (3) If asking the Password, move each digit using LEFT() , RIGHT() Key, input password and press the ENTER() Key using UP() , DOWN() Key.
- (4) After input correct password, when pressing the RIGHT() Key, OPEN COUNTER number flashes.
- (5) Using UP() , DOWN() Key, select a counter number and press the ENTER() Key, then automatically saved.
- (6) After setting, if you press the LEFT() Key, go out to the OPEN COUNTER setting screen.

4.4 TEST FUNCTION METHOD

TEST menu of K-PAM F300 has a contacts Test for relay operation, relay front Display test.

4.4.1 DISPLAY TEST

SETTING/TEST/DISPLAY TEST is a menu to test the 16 LED and LCD in front panel of relay.

When front DISPLAY Test, all LED on during 1sec, LCD displays "TEST" and all LED, LCD off during 1sec, this test is repeated 3 times.

■ FRONT DISPLAY Test Method

- (1) After in TEST menu screen search to DISPLAY TEST, press the RIGHT()

Key.

- (2) If asking the Password, move each digit using LEFT(◀), RIGHT(▶) Key, input password and press the ENTER(ENT) Key using UP(▲), DOWN(▼) Key.
- (3) After input correct password, if you press the RIGHT(▶) Key, all LED on during 1sec and LCD display "TEST" and all LED, LCD off during 1sec.
- (4) This test is repeated 3 times and switch to TEST menu screen.

4.4.2 CONTACT TEST

SETTING/TEST/CONTACT TEST is a menu to test the 10 output contacts of relay. When screen switched, displayed all of the current state of output contacts by keeping.

■ Output Contacts Test Method

- (1) After in TEST menu screen search to CONTACT TEST, if you press the RIGHT(▶) Key, output contact Test screen will appear.
- (2) Select a test output contact using UP(▲), DOWN(▼) Key and press the RIGHT(▶) Key.
- (3) If asking the Password, move each digit using LEFT(◀), RIGHT(▶) Key, input password and press the ENTER(ENT) Key using UP(▲), DOWN(▼) Key.
- (4) After input correct password, if you press the RIGHT(▶) Key, current contact status "DnE", "Ene" flashes.
- (5) Whenever you press the UP(▲), DOWN(▼) Key, contact status toggle as "Ene" and "Dne" and relay ON/OFF sound.
- (6) If you press the LEFT(◀) Key, go out to the Test screen and contact status hold to last test status.
- (7) If you want to other output contact test, repeat to (2) ~ (6).
- (8) When retake a test, does not asking the password and if you do not want to output contact test, go out to the test screen using LEFT(◀) Key.
If you out of the test screen, restored as previous output contact status.

5. PC Software

PC Software is an Application Software designed to use this relay(K-PAM F300) conveniently using PC or Notebook.

PC Software is composed of KBIED_MNE and KbCanes.

KBIED_MNE has the functions such as relay setting and file storage, Verification and Text file type storage of Event Data, Verification and Comtrade file Type Storage of Fault Waveform(Waveform Data), Verification of each Phase Voltage and Line-line Voltage, Sequence voltage, Frequency, Frequency input voltage and Monitoring the relay element operation status and relay self diagnosis status.

KbCanes can verify and analyze the fault wave forms, that are stored in Comtrade File type by the relay using KBIED_MNE, in the Graphic mode.

The fault wave forms stored in the relay are Digital signals converted from Analog signals through A/D Converter after the voltage input to the relay passed through the Analog Filter inside the relay.

The fault waveform is 32 Samples per 1 Cycle, and KbCanes expresses the waveform in Graphic form using the Digital signal.

5.1 KBIED_MNE

As you can set various settings and system configuration related settings in menu of the K-PAM F300 relay itself, you can set collectively from remote PC or notebook using this KBIED_MNE.

You can use KBIED_MNE in not only RS-232C communications, but also RS-485C communications, and you need to change the protocol to ModBus when using RS-485C communications.

When you change the settings in the relay, you have to repeat the changing work for each category, but if you use KBIED_MNE, you can work collectively, and you can also store the contents of the changes as a file, so you can change more conveniently when you work on the same task.

5.1.1 Application Software Program Install Method

To install the application software program, download KBIED_MNE_SETUP.zip from KyongBo Electric Homepage. If you unzip it, KBIED_MNE setup folder will appear.



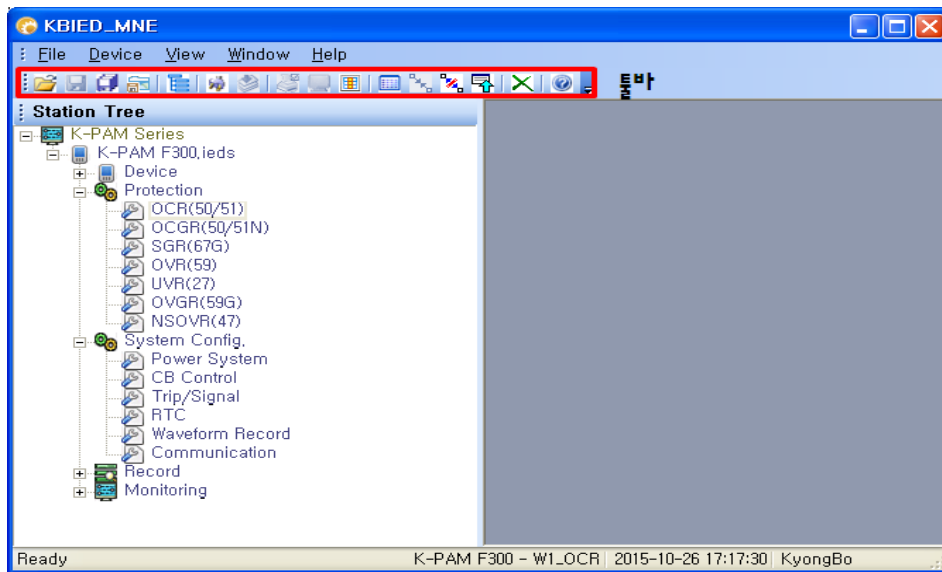











Double click on the **Setup.Exe** file and install the program. After the installation is completed, to execute Setting Tool Program, double click on the **KBIED_MNE.exe** file of the wallpaper. When KBIED_MNE is run, the following screen appears.



<Figure 18. KBIED_MNE Initial Display>

5.1.2 KBIED_MNE Program Menu

The basic menu of KBIED_MNE is largely divided to Protection element Setting, Setting Menu related System, Monitoring of the Relay measurement and status, and please refer to the following table for details.

● Program Menu	
 Open Project	Load the saved project file.
 Save Device	Save setting for Protection element and system setting
 Save All	Save all changes to protection elements and setting in all open window
 Save Project	Save Project tree of left window
 Edit Devices	Add, delete or change protection relays to the project.
 Direct Connect	it is used for direct connection with protection relay.
 Write Device Saved Settings File (PC→Device)	Transmits Setting changes of System and Protection to the Relay
 Print	Print the saved data.
 Compare Device Settings with Settings File	Compares the data of relay with the data saved in the pc.
 Export Setting File	Save the setting value as a TEXT document.
 Connect Status/Metering	Connect communication to verify status and measurement.
 Disconnect Status/Metering	Disconnect communication
 Relay → PC	Automatically reads the setting value saved in the relay
 Close All Windows	close all pop-up windows.
 Customer support	The menu is informed company website and email address

<Table 17. KBIED_MNE Program Menus>

5.1.3 Create Project (Edit Devices)

KBIED_MNE can manage the protection relay file as much as you want by using one project file. To create a project file, first select the Edit Devices menu and a window will be created to add, delete or modify the protection relay as shown below.

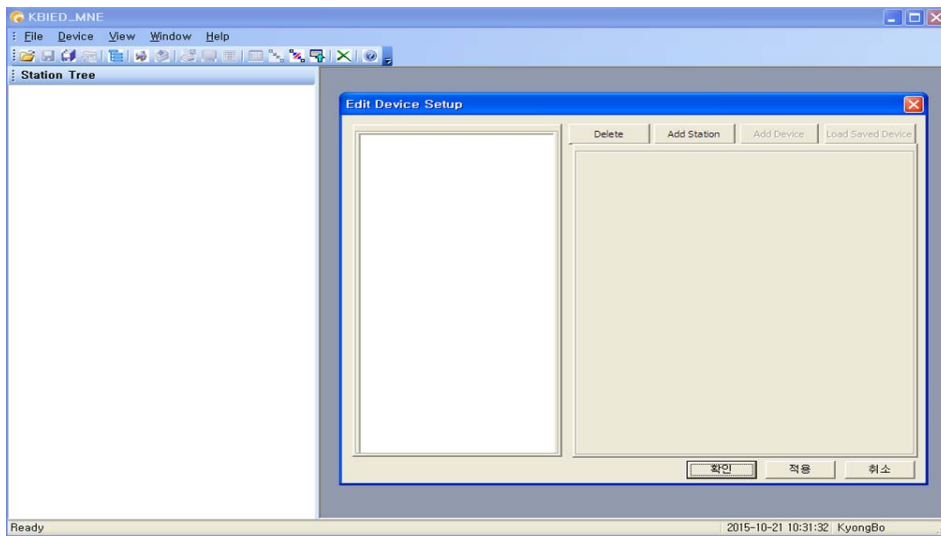

<Figure 19. Edit Devices Screen>

5.1.3.1 Station

If you press 'Add Station' button in Edit Devices window, information for creating station appears as below picture. And enter station name will create station in the left window.

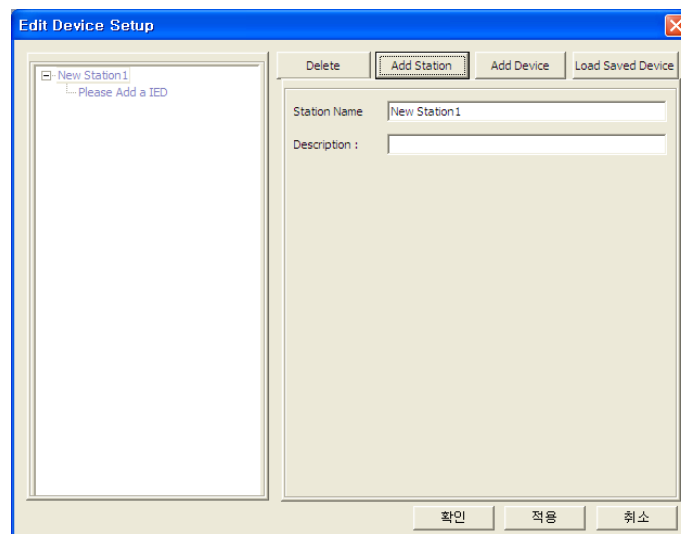

<Figure 20. Edit Devices - Station Screen>

5.1.3.2 Device

If 'Add Device' is pressed as shown in the figure below, information for creating a protection relay will be displayed. Enter information for the protection relay and selecting communication interface. Then Input information for setting the corresponding communication interface appears.

1	IED name	Set the name of protection relay.	
2	Description	Describes the devices.	
3	Device Type	Define the type of protection relay.	
4	Version	Determines the version of the selected protection relay.	
5	Communication	Select the communication interface.	
6	Serial Comm.	Slave Address	Slave address of protection relay for modbus communication
		Com Port	Select the Com Port of the PC to communicate with the protection relay.
		Baud Rate	Decide the communication speed.

<Table 18. Device input information>

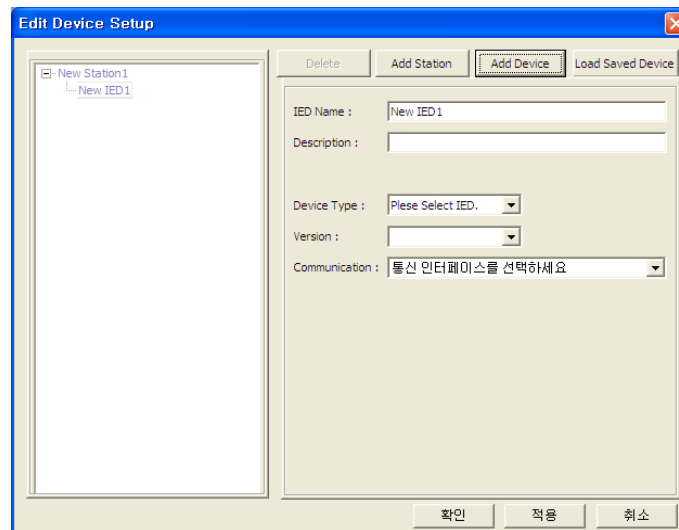

<figure 21-1. Edit Devices - Device screen>

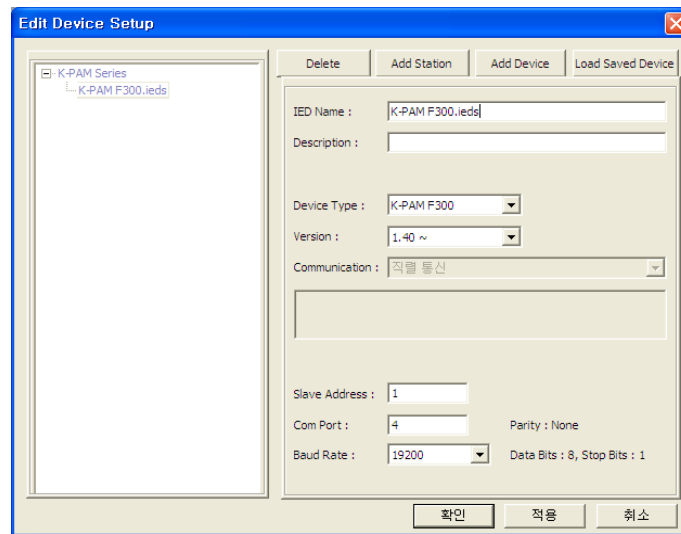

<figure 21-2. Edit Devices - Device screen>

5.1.3.3 Project window

When you complete Edit Devices, the Project Tree is created in the left window as shown below. In the Project Tree, the Device displays information such as Type, Version, Description, Communication Interface, Storage Path, etc. that inform the information of the protection relay.

In addition, the correction tree menu such as Protection, System Config., Record, Monitoring which can change the setting value of protection relay appears.

When you want to view or correct the information, double click the menu tree to display the corresponding window.

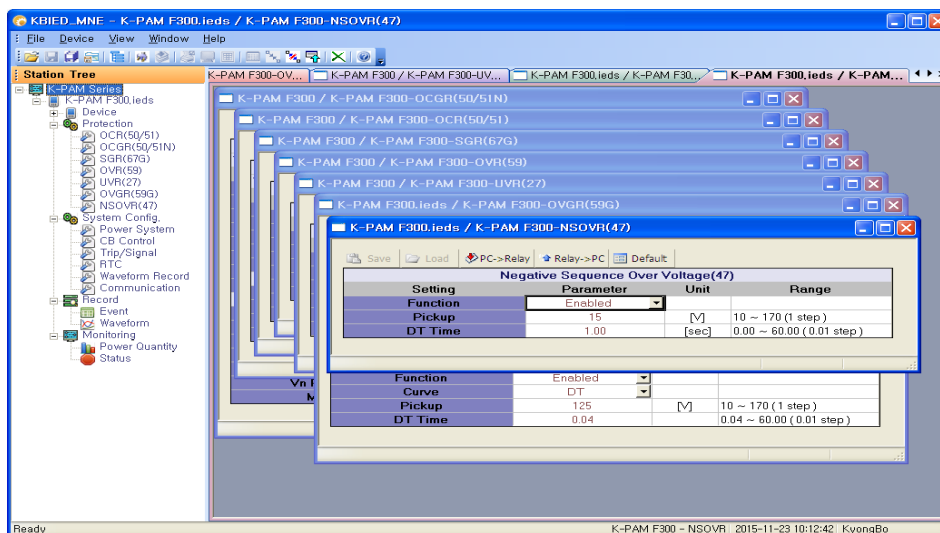

<figure 22. Project Tree screen>

5.1.3.4 Save/Open Project

The Project Tree in the left window can be saved / opened and can be accessed from the File - Save / Open Project menu.

The saved project file only saves the project tree of the explorer. To save the setting of the protection relay, you can save it using Device Save menu.

Device save is described in "5.1.3.5 Device Save" below.

The Device in the Project Tree can be checked whether it is actually stored in the device or not in the search window. This can be identified by the presence of ".ieds" in the device name. That is, if you have the extension ".ieds", then the file with that name exists.

The location of the saved device file appears in the Device - Filepath of the Project Tree.

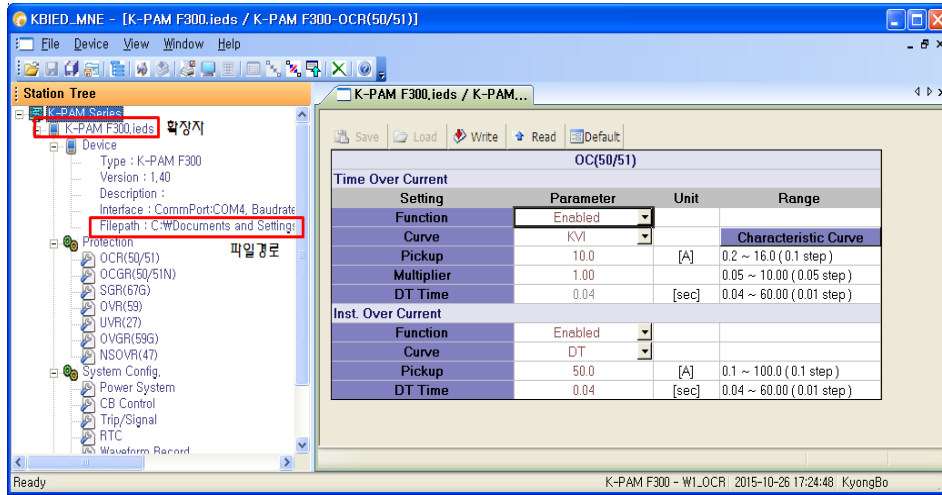

<figure 23. Project save screen>

5.1.3.5 Save Device

To save the Device file, double-click the desired correction item in the Device Tree.

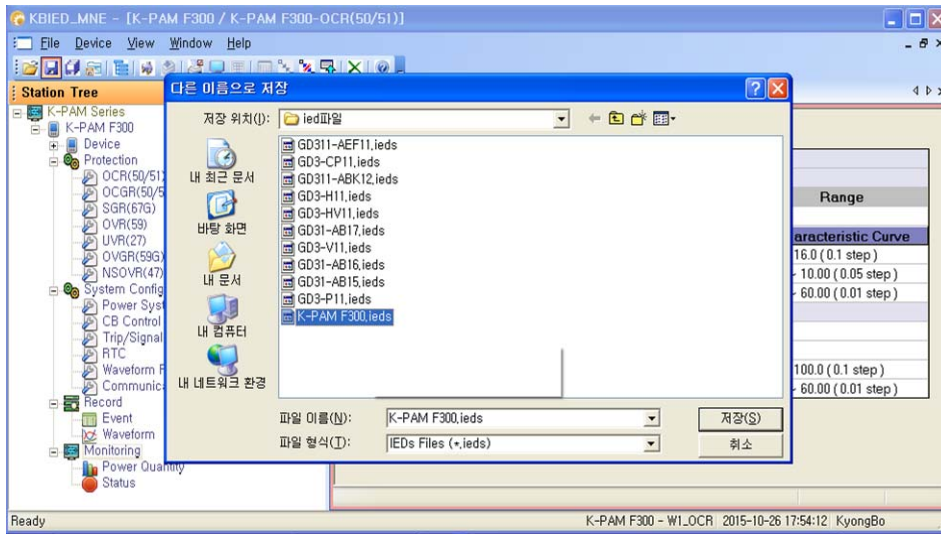

Select Device Save from the File menu and save using the file save window, then the value of the current window is saved. Other settings are saved as the product shipping setting value. Refer to "5.1.3.6 Setting Window Menu"



<figure 24. Device save screen>

5.1.3.6 Setting window menu

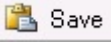
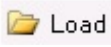
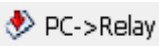
The setting of Device in the search window create windows individually. Save / Load / PC → Relay / Relay → PC / Default is independent for each window.

1		Save the window. After saving, change setting item to brown.
2		The saved data of the window is loaded. After loading, change setting item to brown.
3		Write the setting data to Device. After write, change setting item to blue
4		Read the setting data from Device After read, change setting item to blue
5		Change the setting data to the product shipping setting value. After change, change to black

<table 19. Device setting window menu information>

The items changed by the user will change to red as shown below.

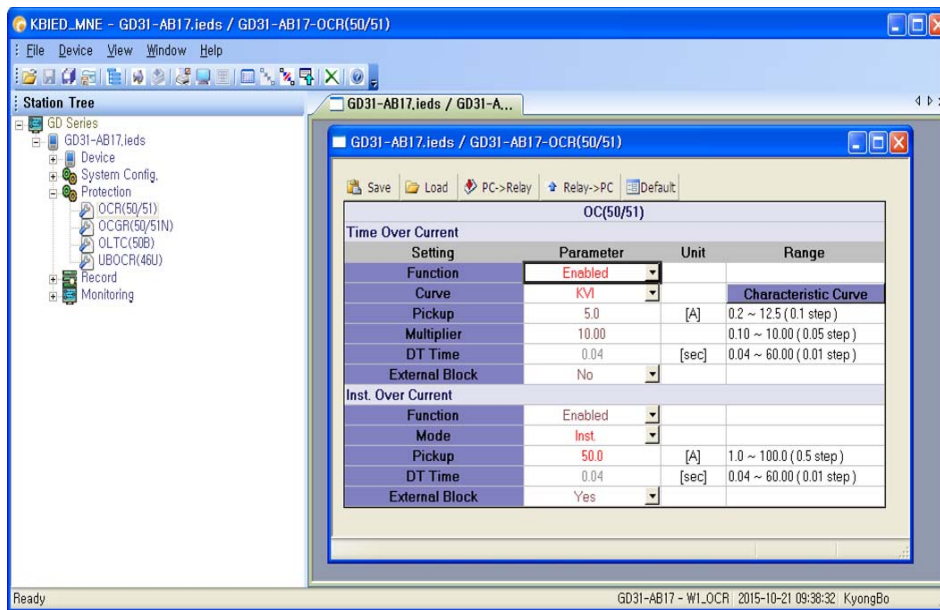

<figure 25. setting window menu screen>

5.1.4 Direct Connect

This function is used to connect the protection relay immediately without creating a Project file. The setting data is the same as the communication setting in Device creation.

If the communication port can not be used by another device, another Com-Port can be selected. The communication port can be used by selecting one of 15 ports.

In addition, RS-232C communication protocol uses ModBus, KBIED_MNE can be used in RS-485 communication.

If you want to use KBIED_MNE in RS-485 communication, first set the relay's address, Connect the RS-485 converter to the RS-232C connector of the notebook and connect it to the RS-485 terminal (51, 52, 53) of the relay.



<figure 26-1. Direct Connect>

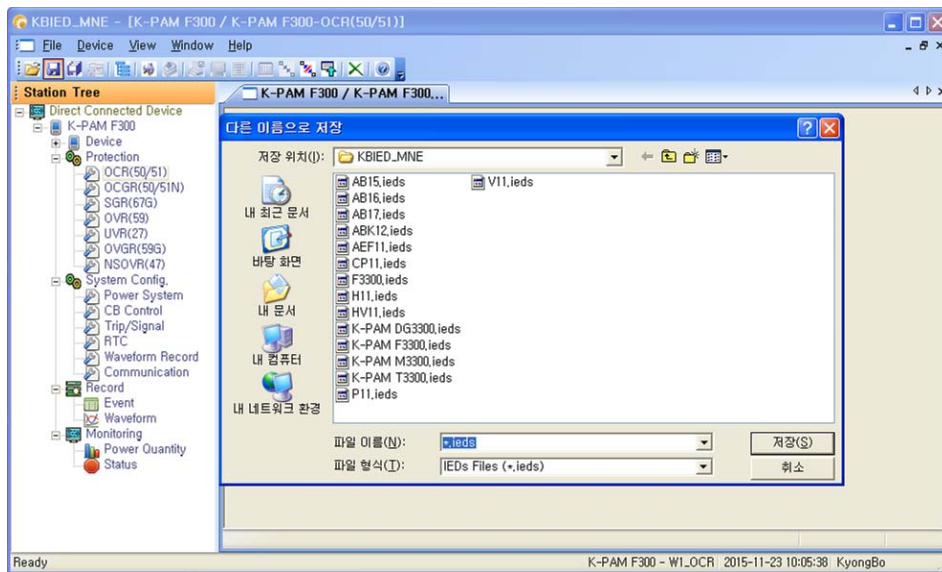

<figure 26-2. Direct Connect ‘ Save Device ’>

5.1.5 Write Device saved Settings Files(PC→Device)

This function is used to download all corrected data from the PC to the protection relay at one time (PC → Device). In the project tree, right-click the saved device ('. Ieds') you wish to download (PC → Device) and use the popup menus or click the saved device ('. Ieds' Files ", you will see an option window to download (PC → Device) as shown below. Press the OK button to download the saved device file from the PC to the Device (Protection Relay) (PC → Device).

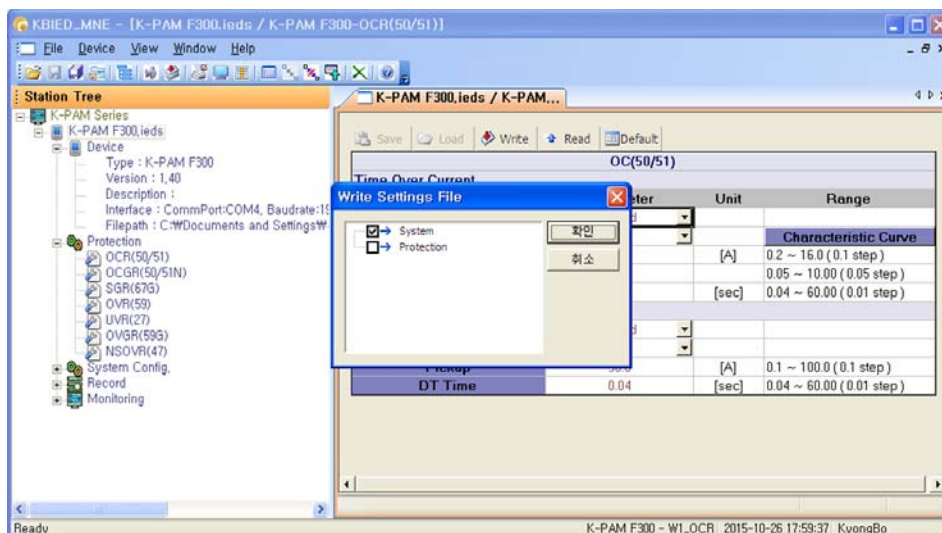

<figure 27. Write device saved setting files (PC→Device)>

5.1.6 Print/Print preview

You can preview the settings to be printed by selecting Print Preview as a function to print the stored device settings.

To preview a print, first select the target device file to be printed in the search window, and then select the Preview menu. The Print Options window will appear as shown below.

Select the data to be printed and insert "Header Line". The preview screen will appear.

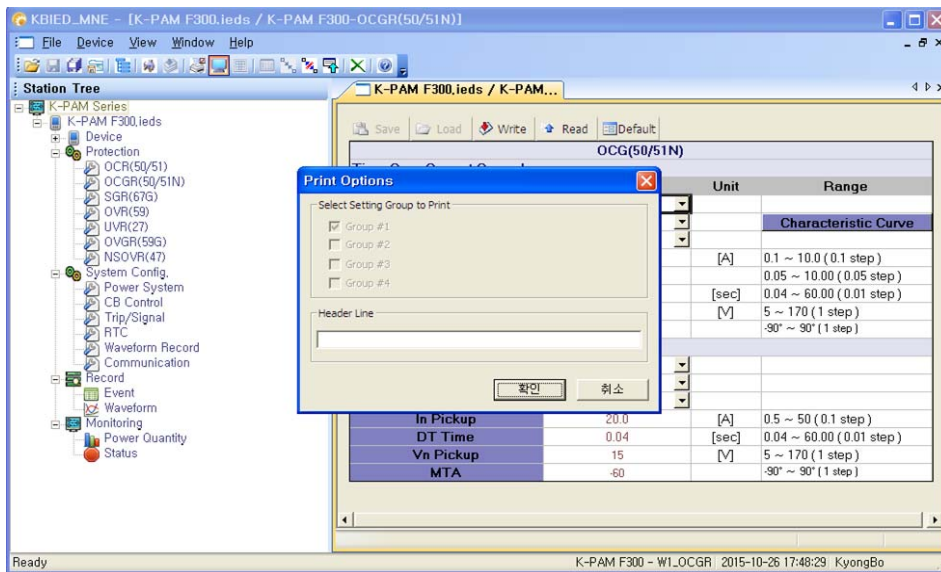

<figure 28. Print Option screen>

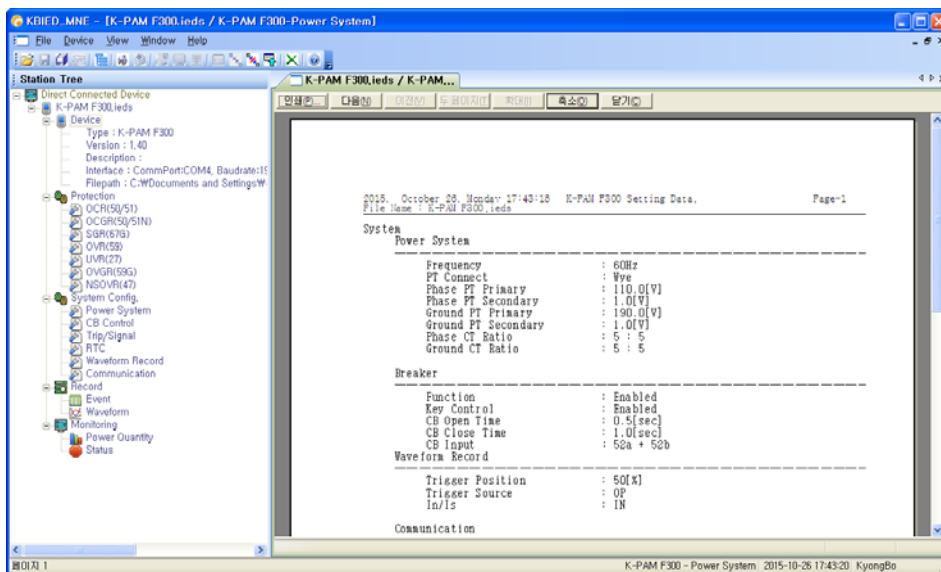

<figure 29. Print Preview screen>

5.1.7 Compare Device Settings with Settings File

This function compares the correction data of the protection relay with the correction data stored in the PC and displays the elements with different values through a separate window. Select the device file you want to compare using the project search window and compare the data with other settings as shown below.

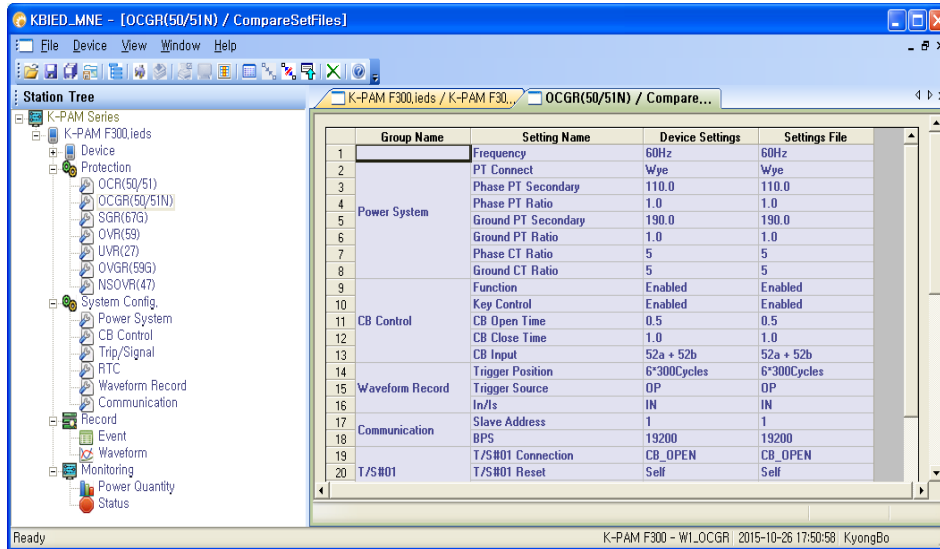

<figure 30. Compare device setting screen>

5.1.8 Export Setting File

It is a function that makes it possible to view corrected data more easily by storing all data of setting value as Text File.

Use the project search window to select the device file to be saved as a text file, and then use the Export Setting File function to create the file.

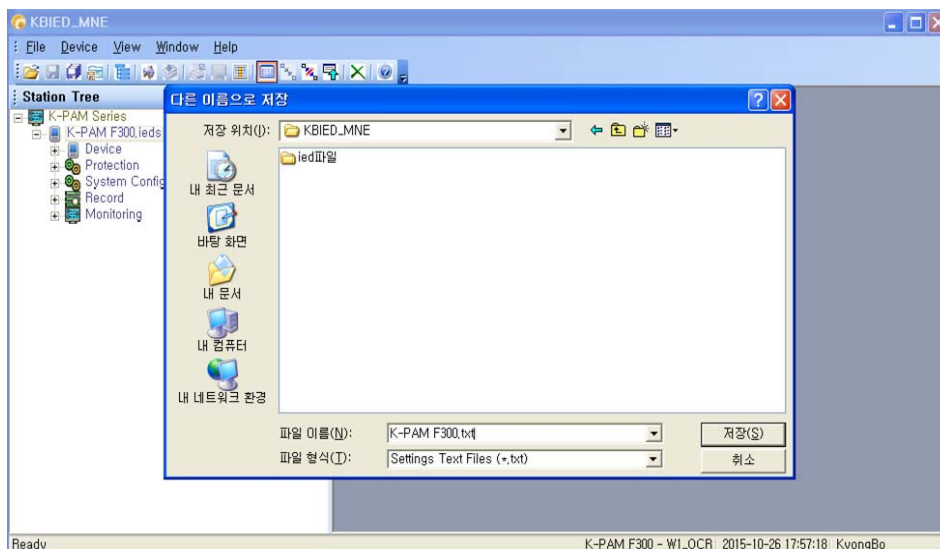

<figure 31. Text save screen>

5.1.9 Event

Click Record / Event category in KBIED_MNE Menu, then a screen that can verify Event Data pops up. In the Event Screen, you can verify Event Data stored, store in Text file format, and delete Event Data stored in the Relay.

Clicking Device → PC (↑) brings Event Data stored in the Relay's non volatile memory(EEPROM) and shows on the screen, and clicking “Event Save” at this state stores the Event Data as *.txt file.

The smaller the number in the Event Data display, is more recent Event Data, and clicking "Clear" deletes the Event Data stored in the Relay.

Event contents are the same as the menu configuration screen of the Relay, so please refer to “3.4.3.1 RECORD ► EVENT”

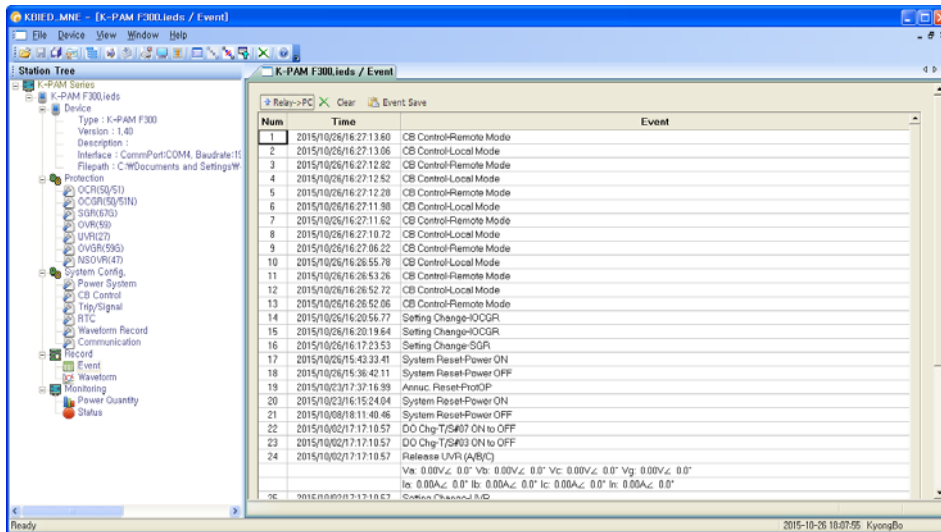

<figure 32. Event>

5.1.10 Waveform

Click Record / Waveform in KBIED_MNE Menu, then a screen where you can verify Waveform Data appears.

Waveform screen can display the fault record information stored in the Relay, convert and store the fault record data as Comtrade File format, and delete desired fault Waveform stored.

Click Device → PC (↑), then Fault waveform(Waveform Data) information stored in the Relay is displayed, and select desired fault waveform with a mouse and click “Save” to convert the fault waveform to Comtrade File format and store from the Relay to PC.

Comtrade file is composed of *.cfg and *.dat files, and these two files are stored as

the same file name with different extensions. These two files are used in fault waveform analysis program(KbCans).

The smaller the number in Waveform Data display, is more recent fault record, and clicking “Clear” deletes the fault waveform record stored in the Relay.

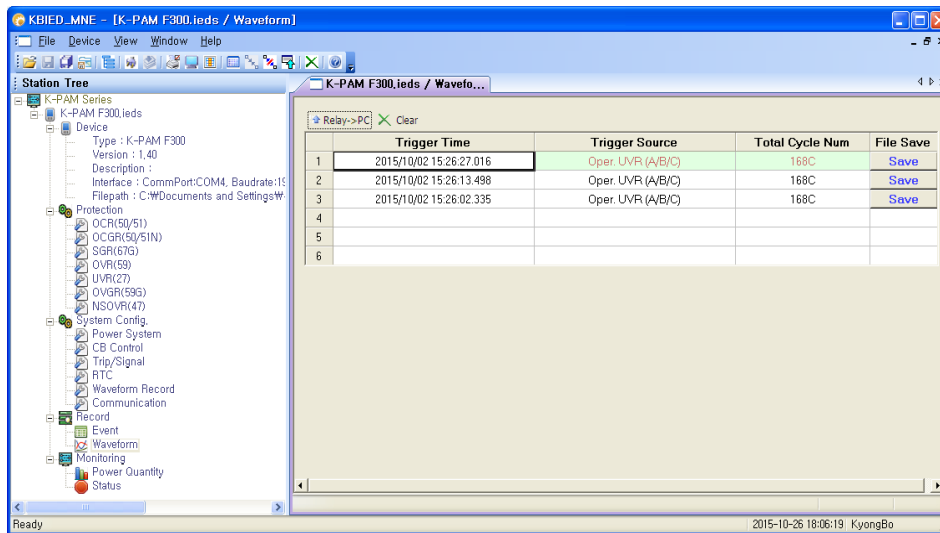

<figure 33. WaveForm>

5.1.11 Power Quantity

Click Monitoring / Measurement category in KBIED_MNE Menu, then a screen that can verify Measurement pops up. Monitoring / Measurement category displays the size and phase of the input phase voltage, the size and phase of the line-line voltage, the size and phase of the zero sequence current/current. the size and phase of symmetrical component(positive-sequence, negative-sequence, and zero-sequence) voltage/current, PF, active/reactive/complex power, active/reactive energy, frequency, CB OPEN number in real time.

Also, to identify the 3 phase voltage/current input to the Relay more easily, clicking "Vector" on Measurement category at the top, it displays as a Graph of the Monitor Display and clicking “Energy Clear” deletes the active/reactive energy stored in the Relay.

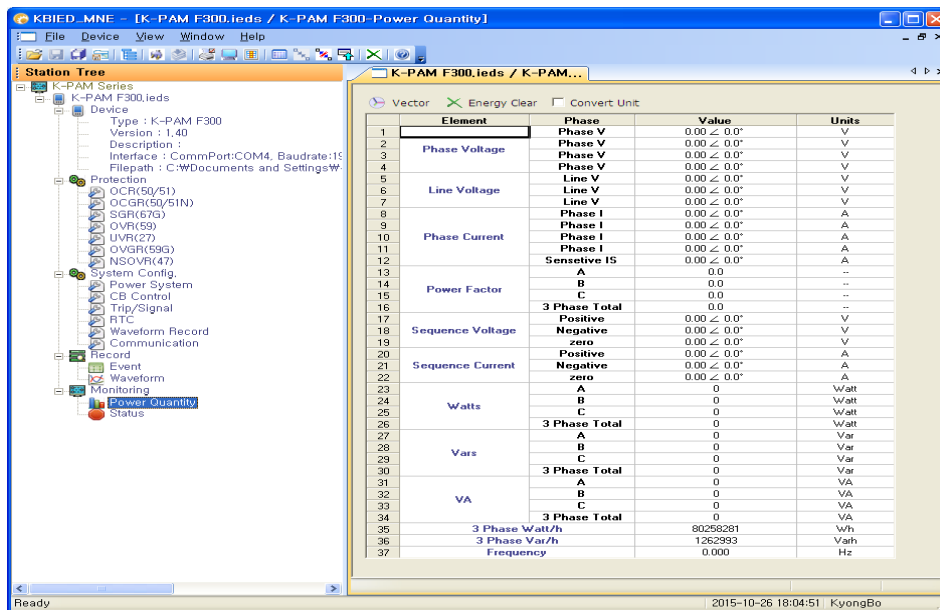

<figure 34. Power Quantity>

5.1.12 Status Screen

Click Monitoring / Status category in KBIED_MNE Menu, then a screen that can verify status of relay pops up.

Monitoring / Status category displays the self diagnosis status of relay, protection element operation status, input/output contacts status etc. in real time.

If System / T/S output / CON category set to SYS_ERR, operation status of contacts display the Red, when self-diagnosis is normal.

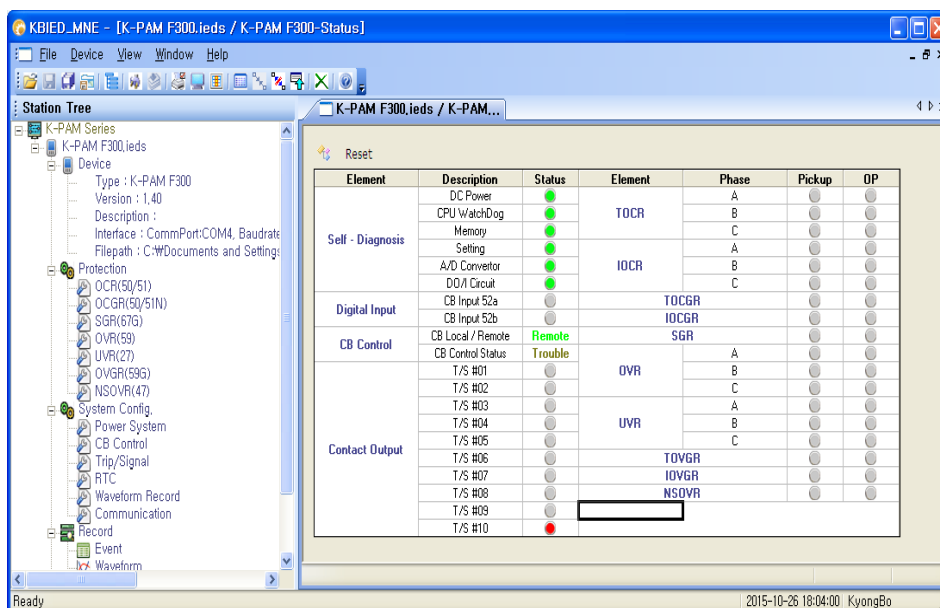

<figure 35. Status>

※ KBIED_MNE Communication Method

You can follow the procedures below to use KBIED_MNE program to communicate with the relay.

※ In case there is RS-232C Communication Port on PC or Notebook

- 1) Connect RS-232C Cable Female connector which our company supplied to RS-232C Communication Port of PC or Notebook
- 2) Connect RS-232C Cable Male connector to RS-232C communication port of the relay
- 3) Input AC/DC 110~220V power to the control power connectors(No. 21 and 23) of the relay
- 4) Select **Connect**() in File menu of KBIED_MNE.

※ If there is no RS-232C Communication Port in PC or Notebook

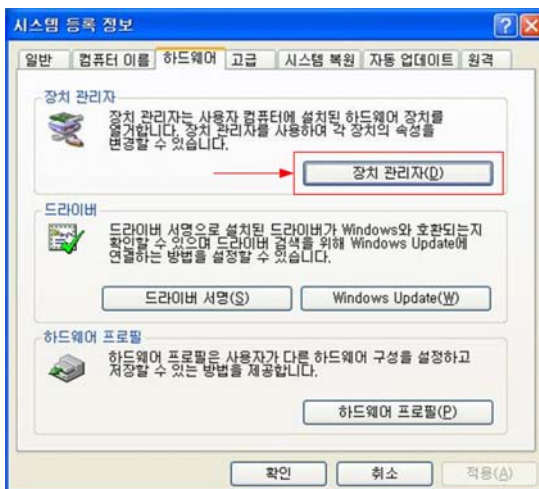

- 1) Purchase USB To RS-232C Cable, and connect USB To RS-232C Cable to USB Port
- 2) Install Cable Driver into the Computer using the installation CD in the package of purchased USB To RS-232C Cable
- 3) Click right mouse button on **My Computer** icon in the Computer Background Screen, and select **Attribute** from the pop up menu.
- 4) Select **Hardware** menu from the System Registration Information, and click **Device Manager**
- 5) Select **Port(COM and LPT)** in the Device Manager, and verify the COM Port Number that the computer recognized

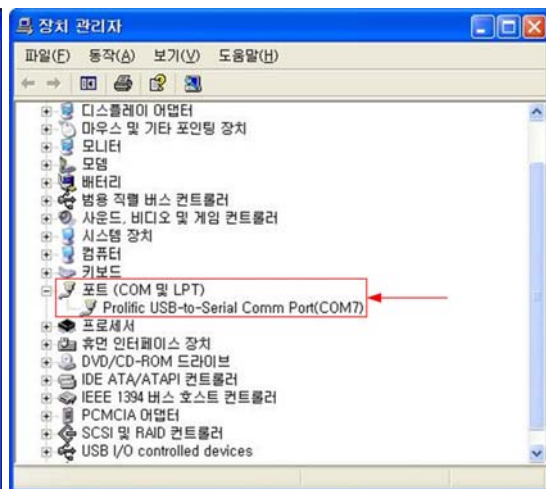

<figure 36. System Config>



<figure 37. Device Supervision>

- 6) Select **Comm.port**() in KBIED_MNE **File** menu, select COM Number that the computer recognized in the COM Port Settings, and click “**Apply**” button
- 7) Connect RS-232C Cable Female connector which our company supplied to RS-232C Communication Port of PC or Notebook
- 8) Connect RS-232C Cable Male connector which our company supplied to RS-232C Communication Port of the relay.
- 9) Input AC/DC 110~220V power to the control power connectors(No. 21 and 23) of the relay
- 10) Select **Connect**() in KBIED_MNE **File** menu

6. Install and Connection

6.1 Dimensioned Drawings

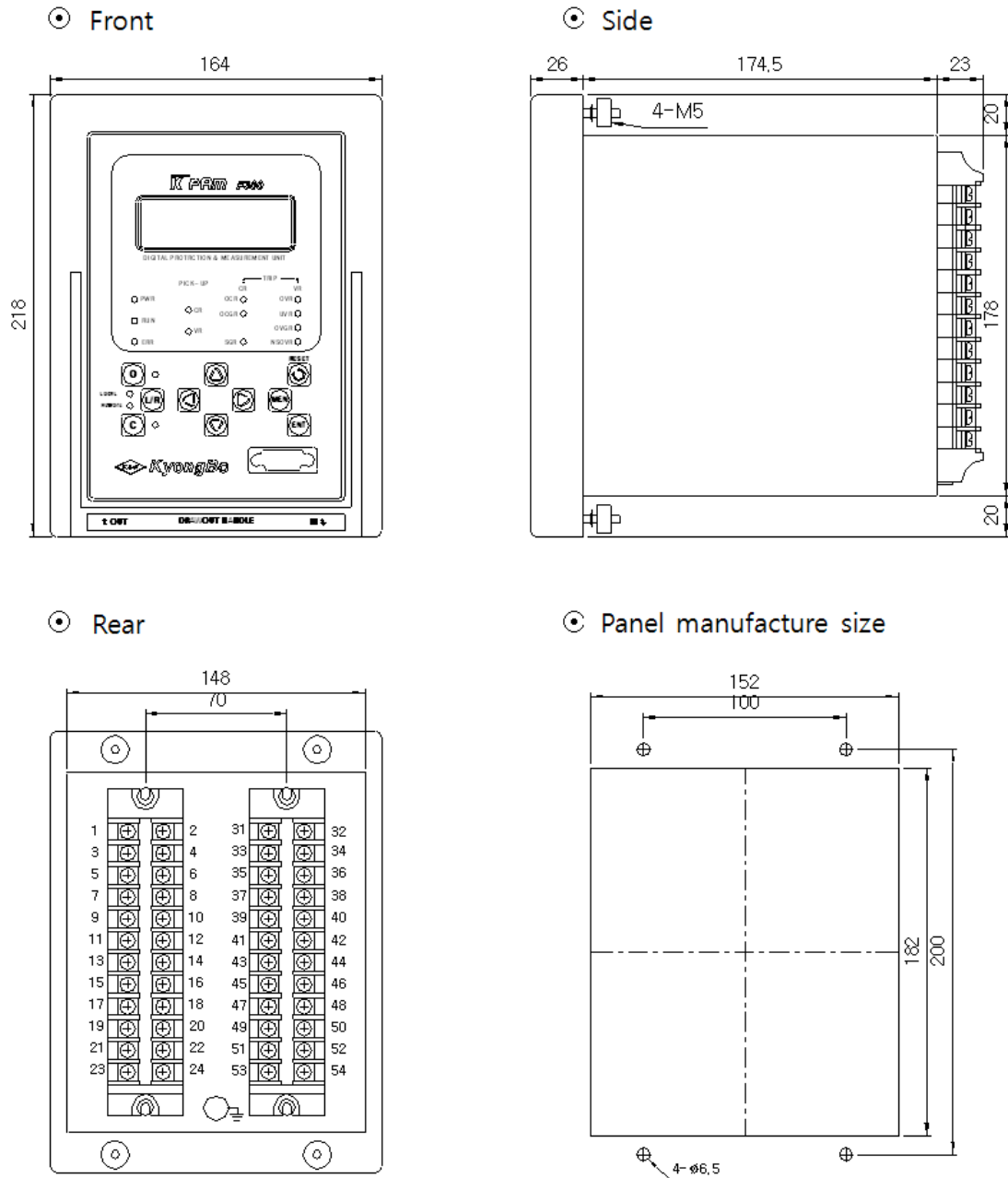

<Figure 38. K-PAM F300 Dimension>

6.2 Rear Terminal layout

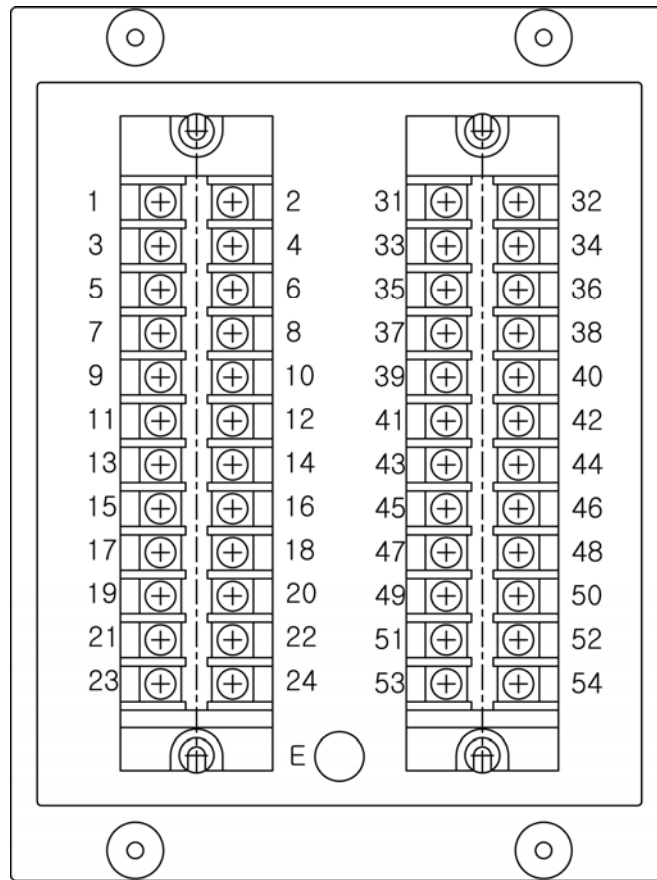

1	TS1_NO	2	TS1_COM	31	IA+	32	IA-
3	TS2_NO	4	TS2_COM	33	IB+	34	IB-
5	TS3_NO	6	TS3_COM	35	IC+	36	IC-
7	TS4_NO	8	TS5_NO	37	IN+	38	IN-
9	TS6_NO	10	TS4~6_COM	39	VA+	40	VA-
11	TS7_NO	12	TS8_NO	41	VB+	42	VB-
13	TS9_NO	14	TS7~9_COM	43	VC+	44	VC-
15	TS10_NC	16	TS10_COM	45	VN+	46	VN-
17	52a INPUT+	18	52a INPUT-	47	IS+	48	IS-
19	52b INPUT+	20	52b INPUT-	49	-	50	-
21	PWR+	22	FG	51	RS485_DATA+	52	RS485_DATA-
23	PWR-	24	CHASSIS	53	RS485_COM	54	F.G

<Table 19. K-PAM F300 Terminal Layout>

6.3 External Connection

6.3.1 K-PAM F300 External Connection

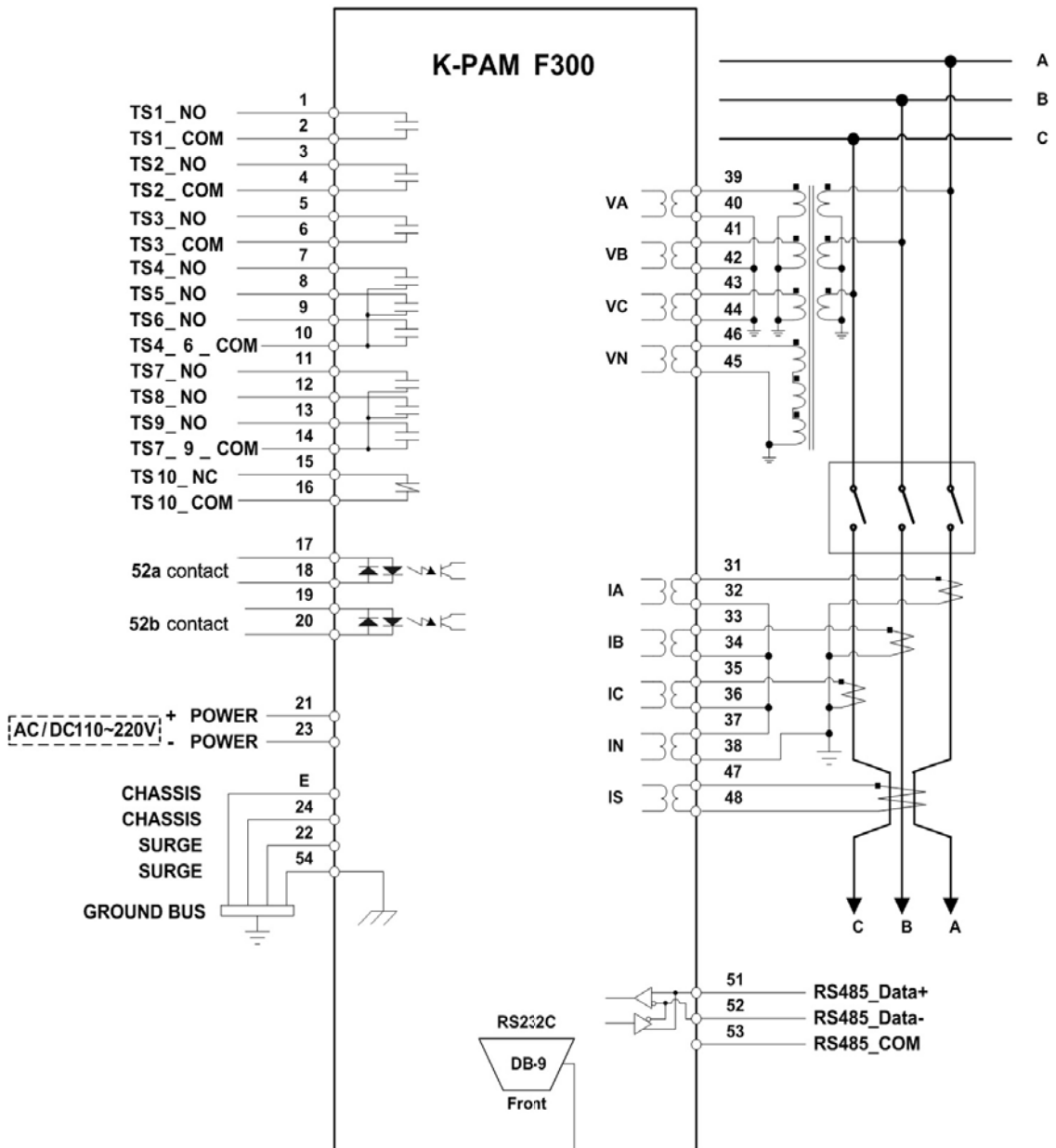

6.3.2 K-PAM F300 PT Connection

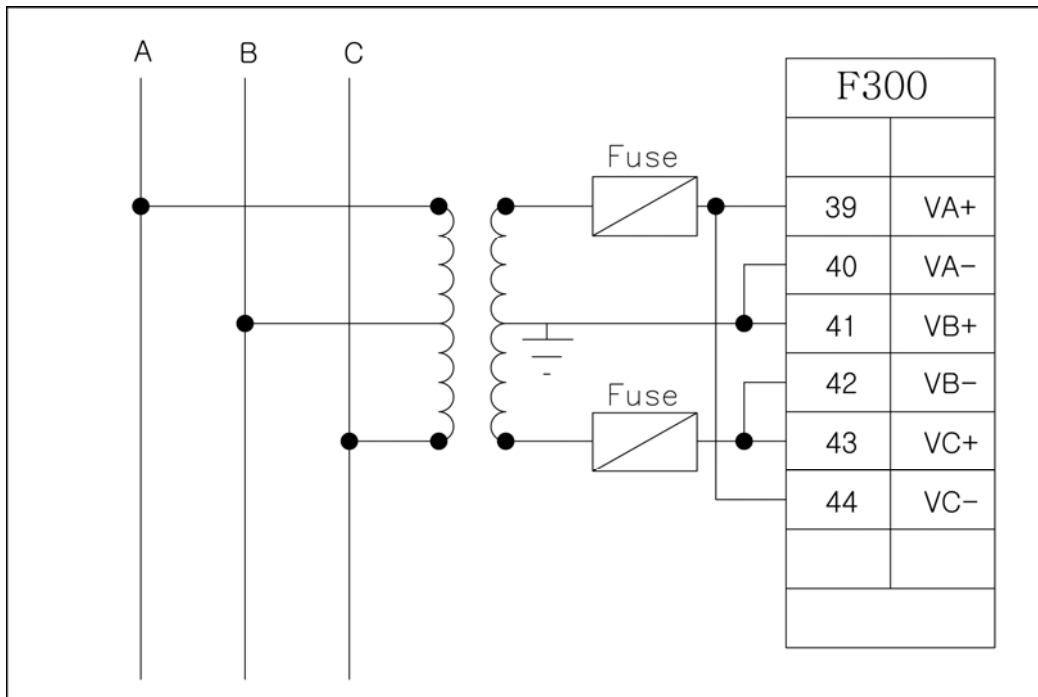

<Figure 39. 3 phase 3 wire system V Connection - ABC Rotation>

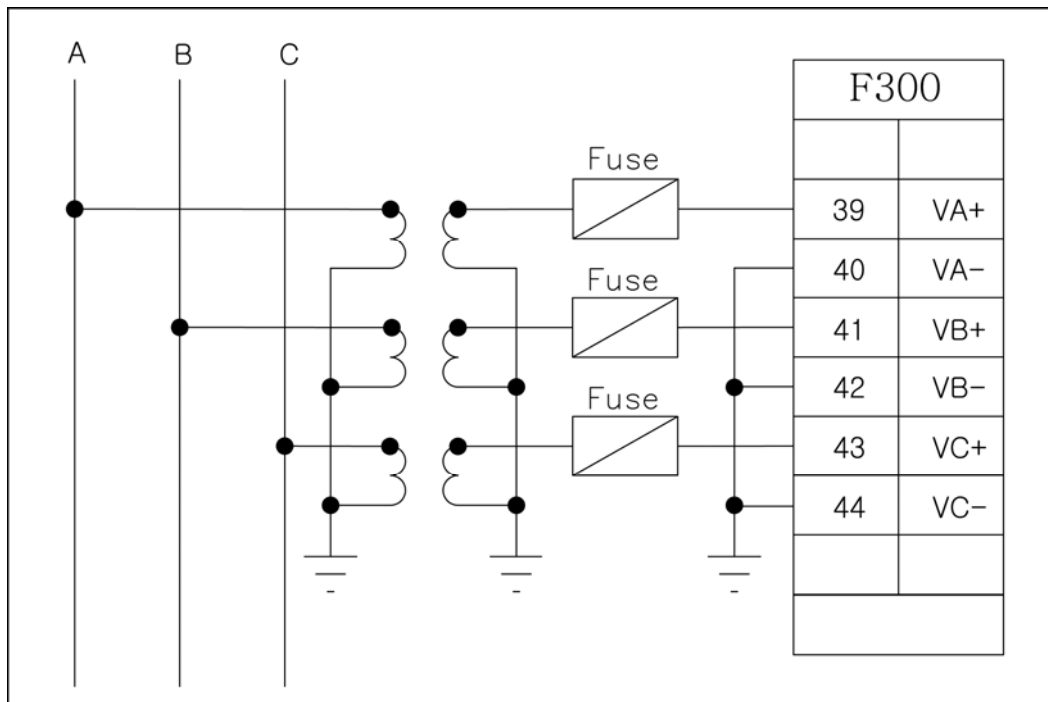

<Figure 40. 3 phase 3 wire system 3PT Connection - ABC Rotation>

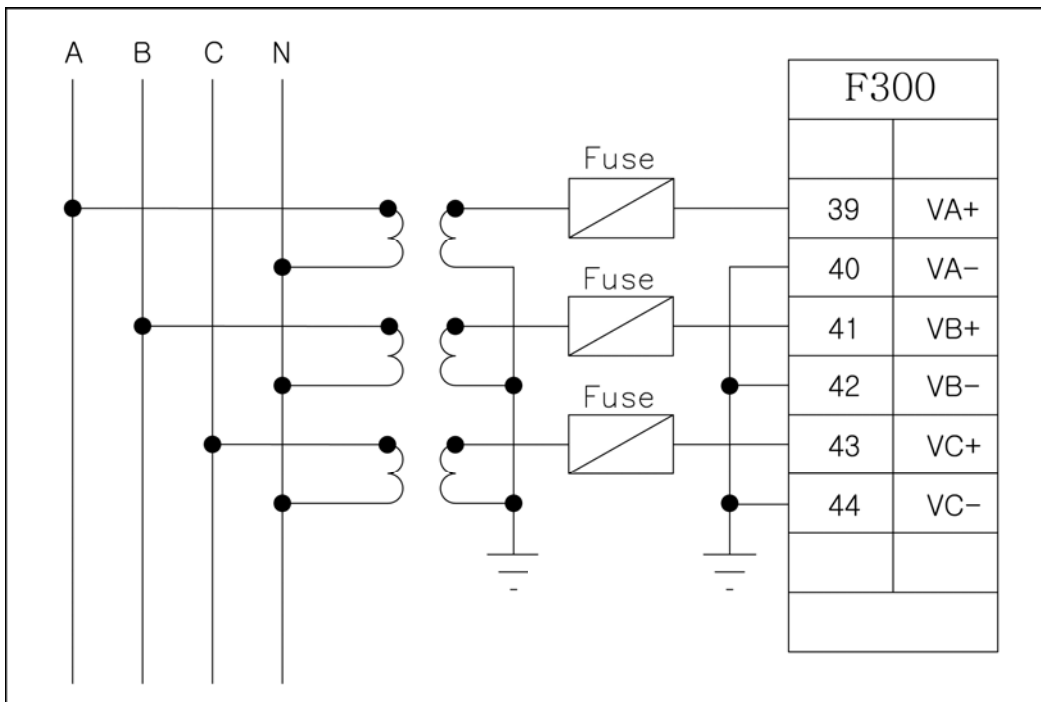

<Figure 41. 3 phase 4 wire system 3PT Connection - ABC Rotation>

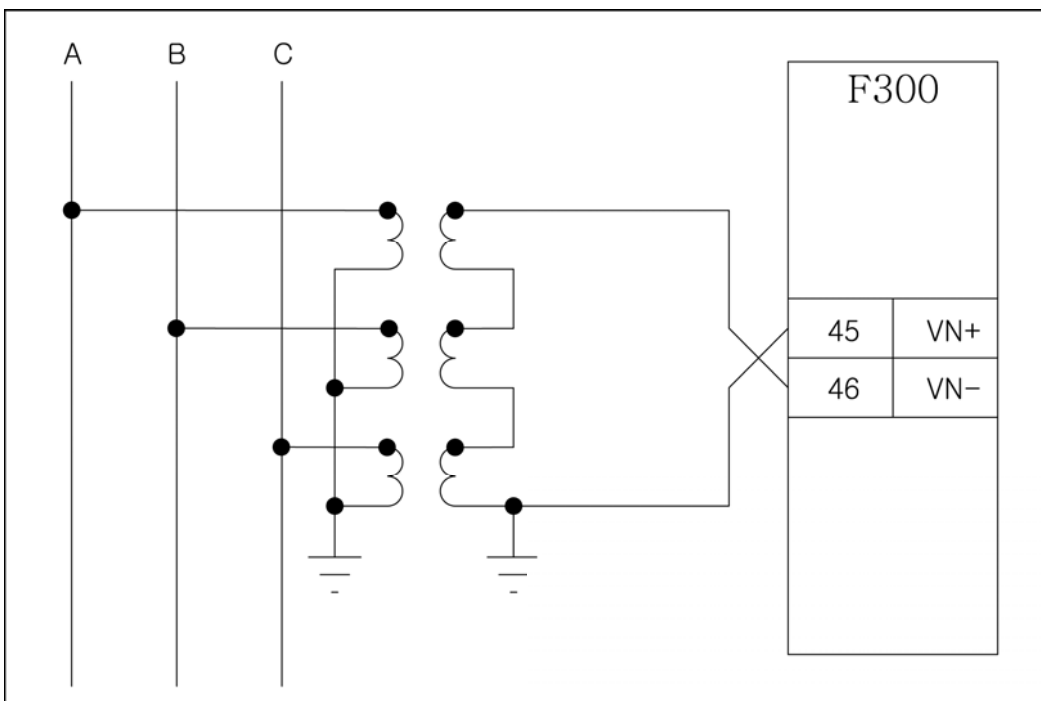

<Figure 42. GPT Connection>

6.3.3 K-PAM F300 CT Connection

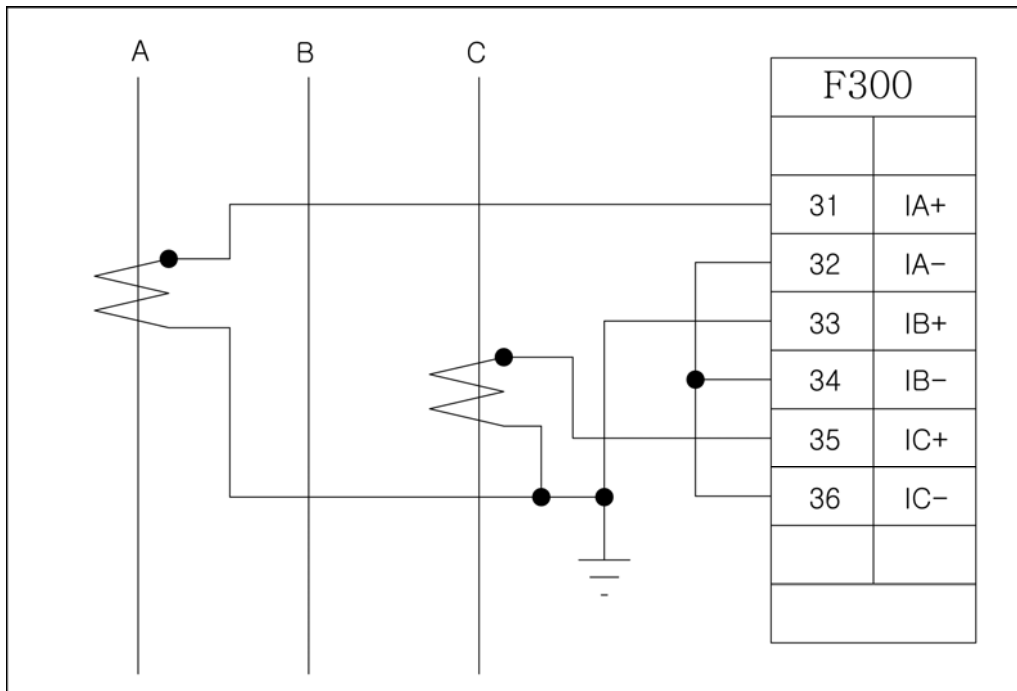

<Figure 43. 3 phase 3 wire system 2CT Connection - ABC Rotation>

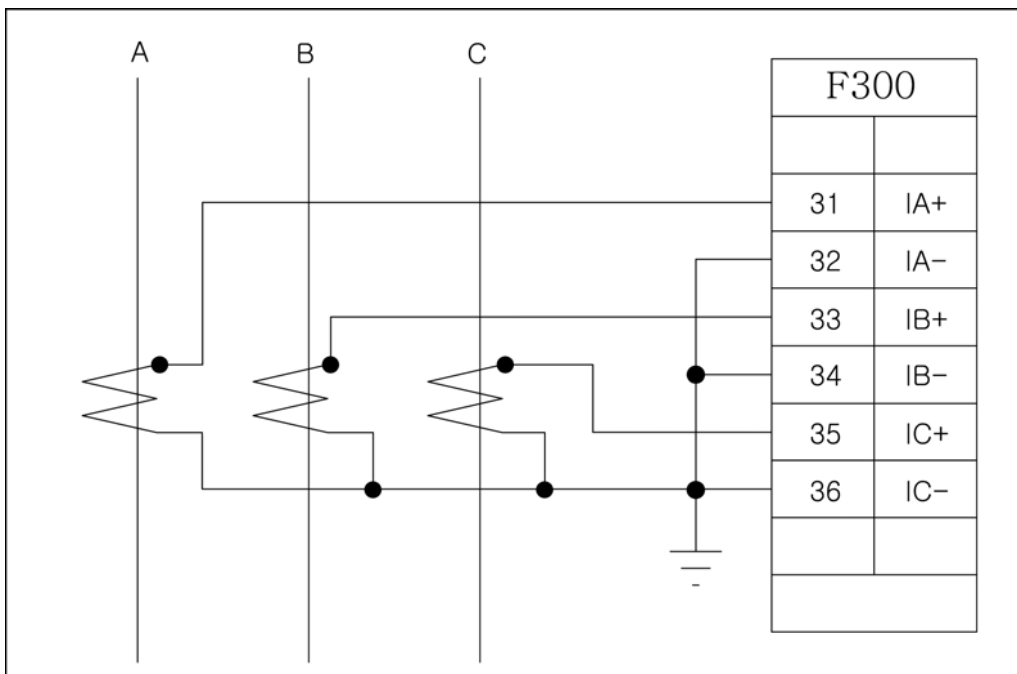

<Figure 44. 3 phase 3 wire system 3CT Connection - ABC Rotation>

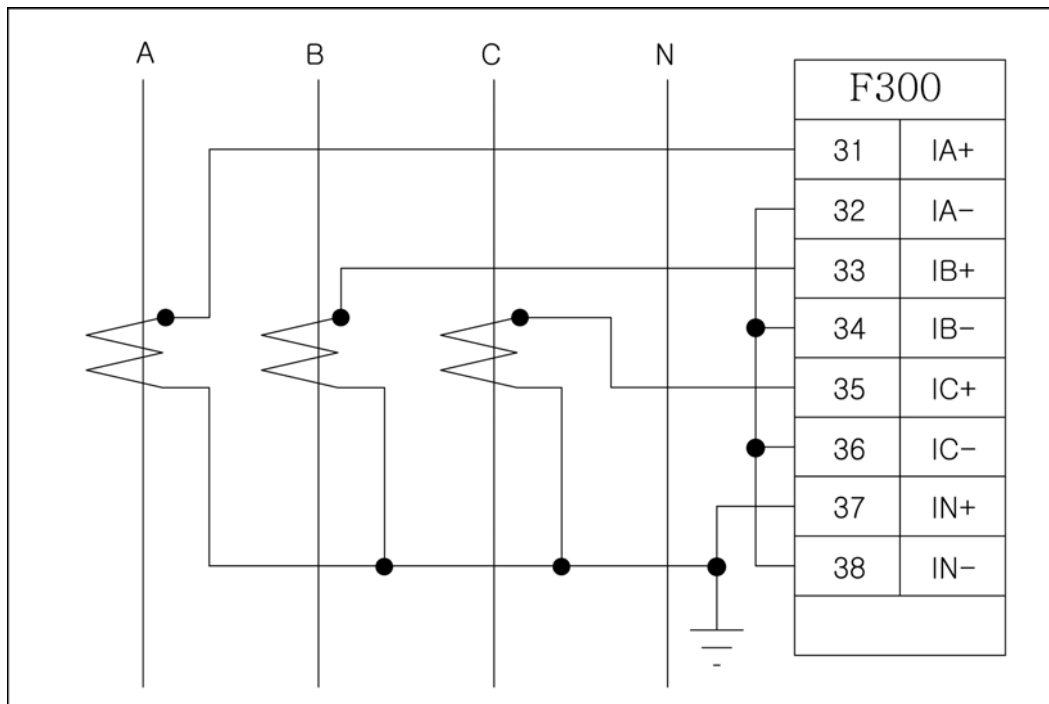

<Figure 45. 3 phase 4 wire system 3CT Residual Circuit Connection - ABC Rotation>

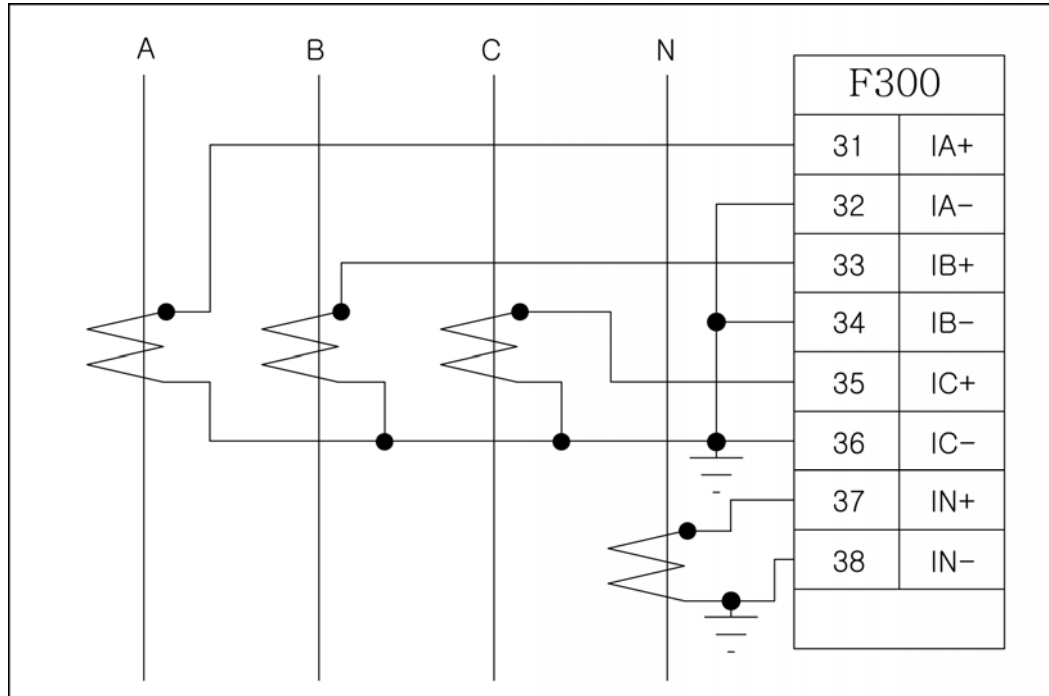

<Figure 46. 3 phase 4 wire system 4CT Connection - ABC Rotation>

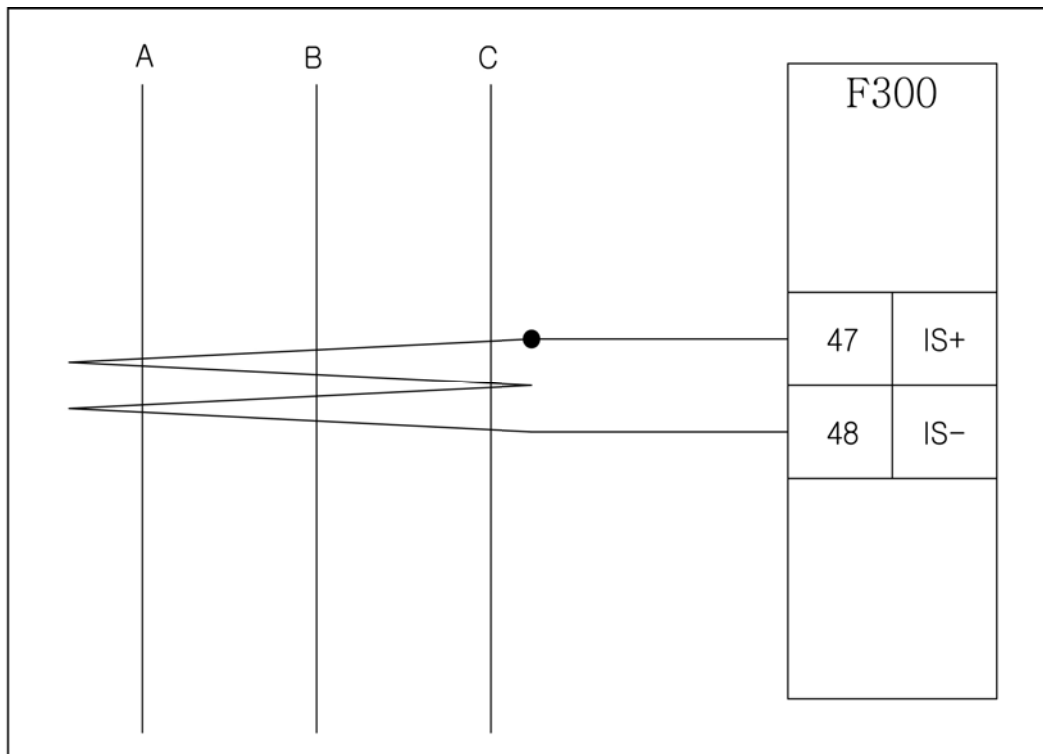

<Figure 47. ZCT Connection>

6.3.4 Input / Output Contact Connection

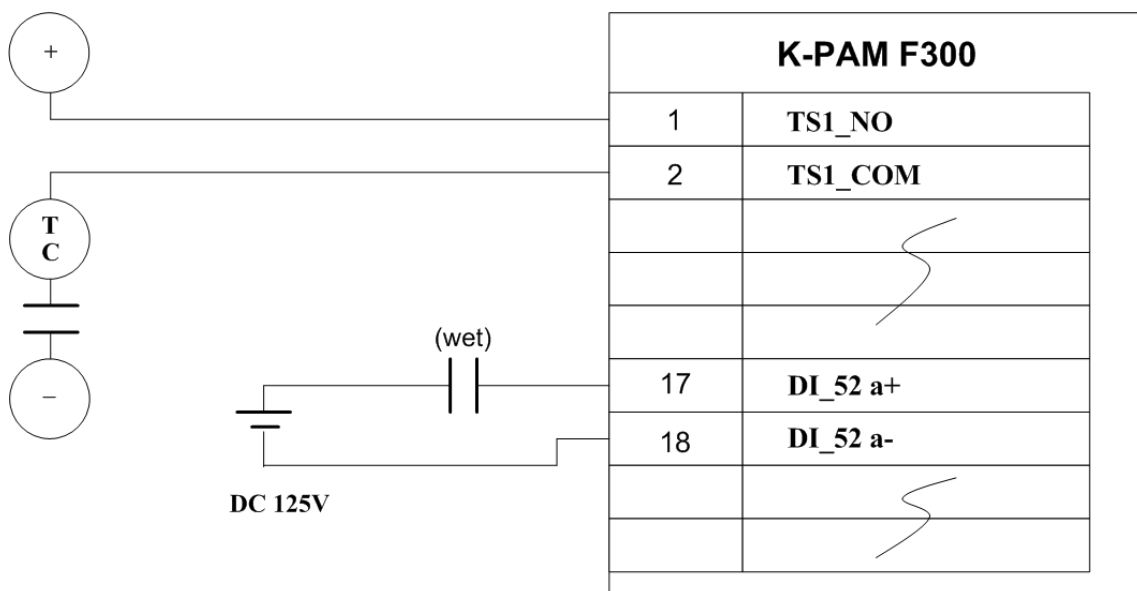

<Figure 48. Input / Output Contact Connection>

6.3.5 RS-232C Communication Port Connection

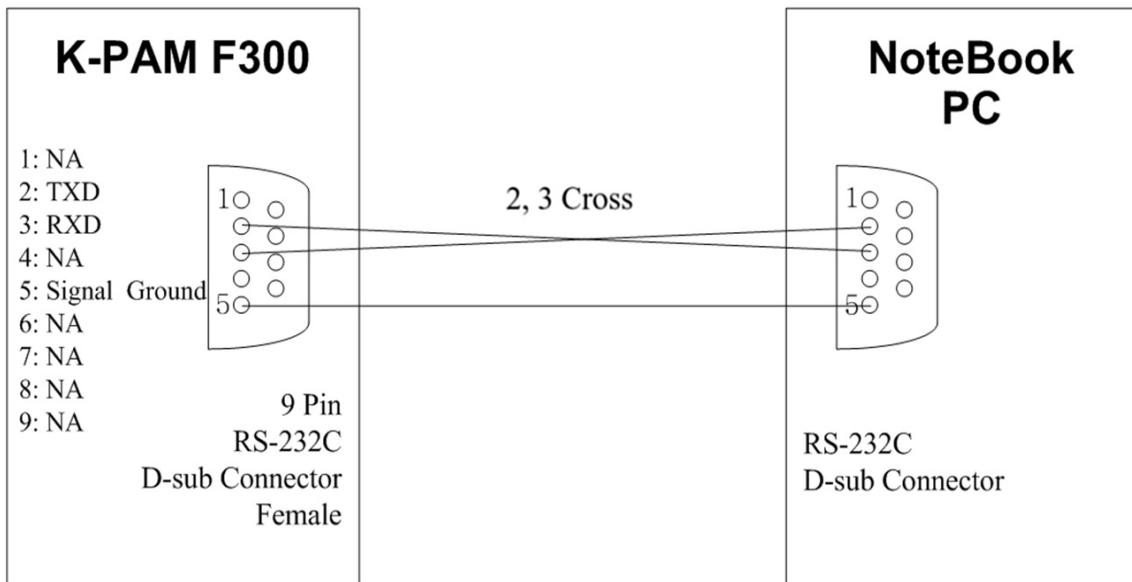

<Figure 49. RS-232C Communication Port Connection>

6.3.6 RS-485C Communication Port Connection

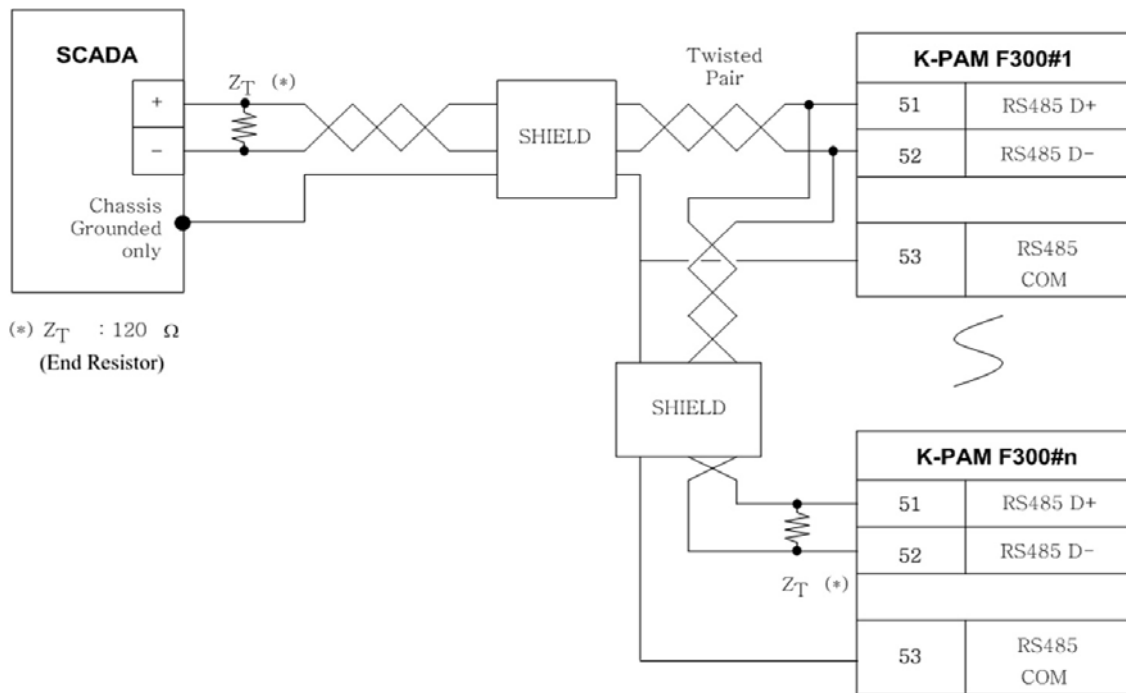

<Figure 50. RS-485C Communication Port Connection>

6.4 Separation and Replacement of Module



CAUTION

You have to install and remove of module in control power is turn off.

If you install and remove to module in control power is turn on, installer suffer electrical injuries or damage of module, malfunction of protection control unit is caused.

6.4.1 Separation of Module

If you grasp the drawout handle under the front panel and raise up, protection control unit is pick out.

And if you loosen the screw of rear and pull, CT/PT module and DO module is separated. Other modules can be separated by loosen the setscrews.

6.4.2 Replace of Module

After the module is separated, it can be replace as board unit.

CT/PT module and DO module fixed terminal and you pushed along the guide-rail, then installed. And you must check a connector connection.

After exchanging a board, other module is installed by tighten a setscrews.

Appended 1. Characteristic Curve

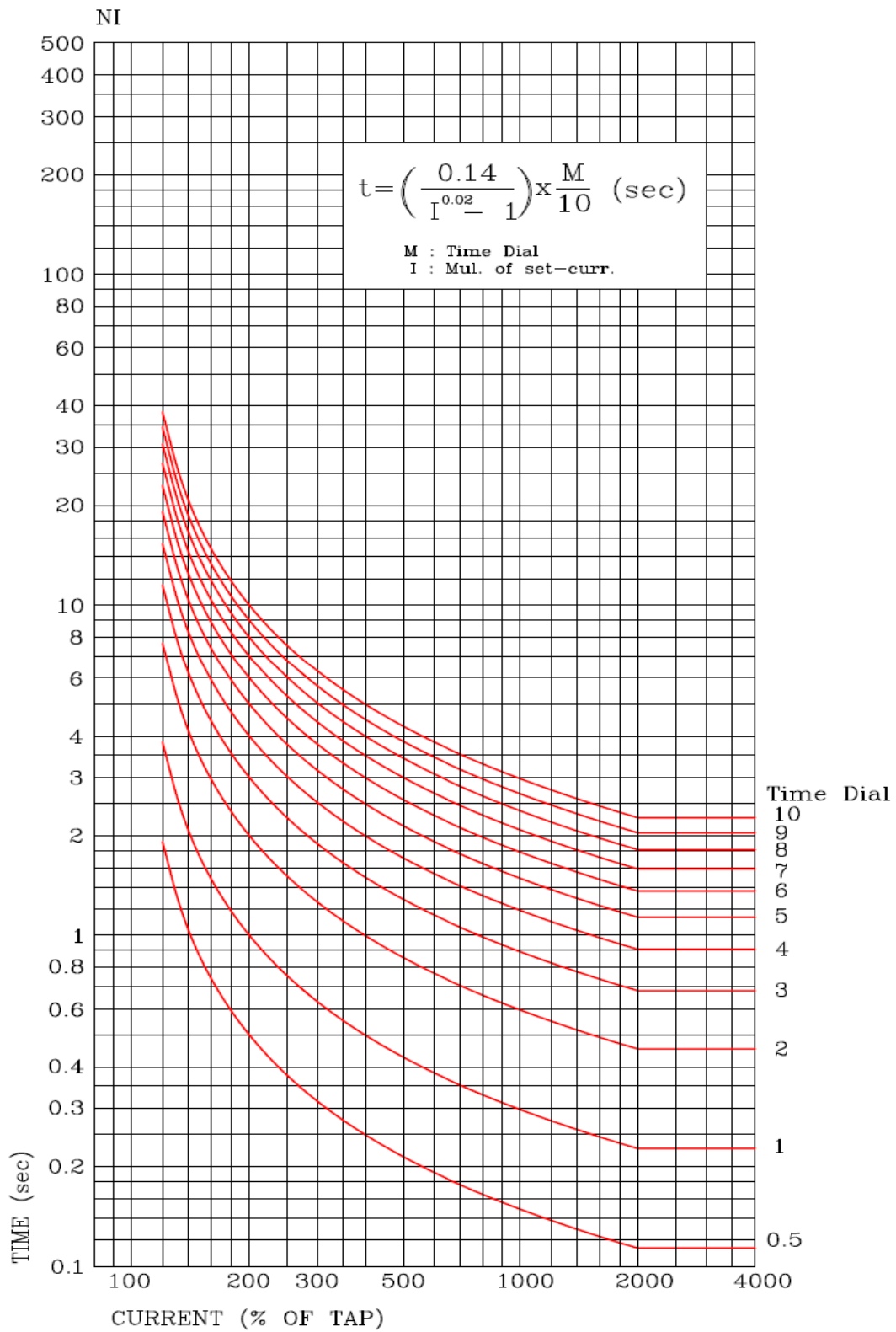

<Appended 1.1 Over-Current/Groud Over-Current NI Characteristic Curve>

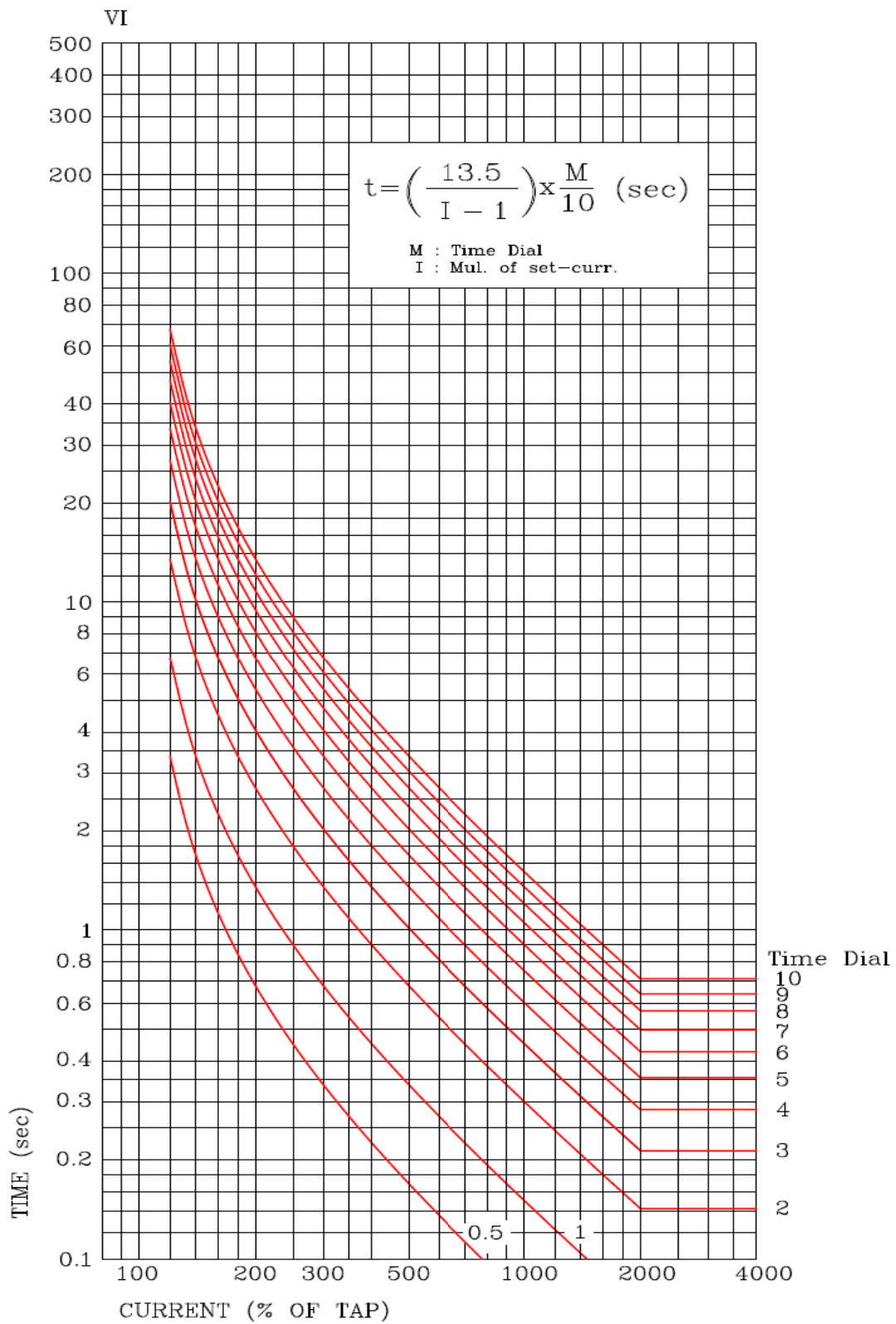

<Appended 1.2 Over-Current/Groud Over-Current VI Characteristic Curve>

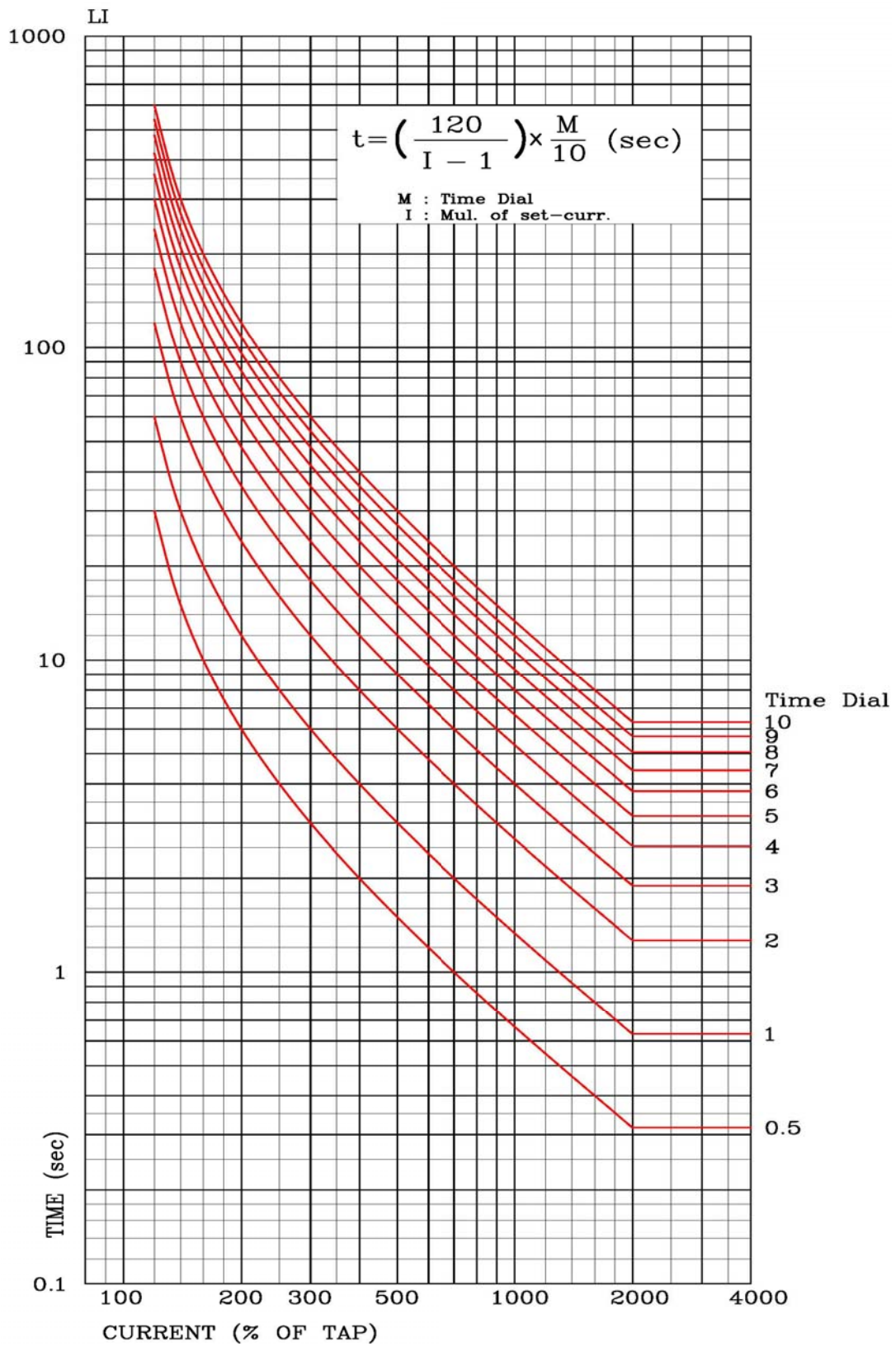

<Appended 1.3 Over-Current/Groud Over-Current LI Characteristic Curve>

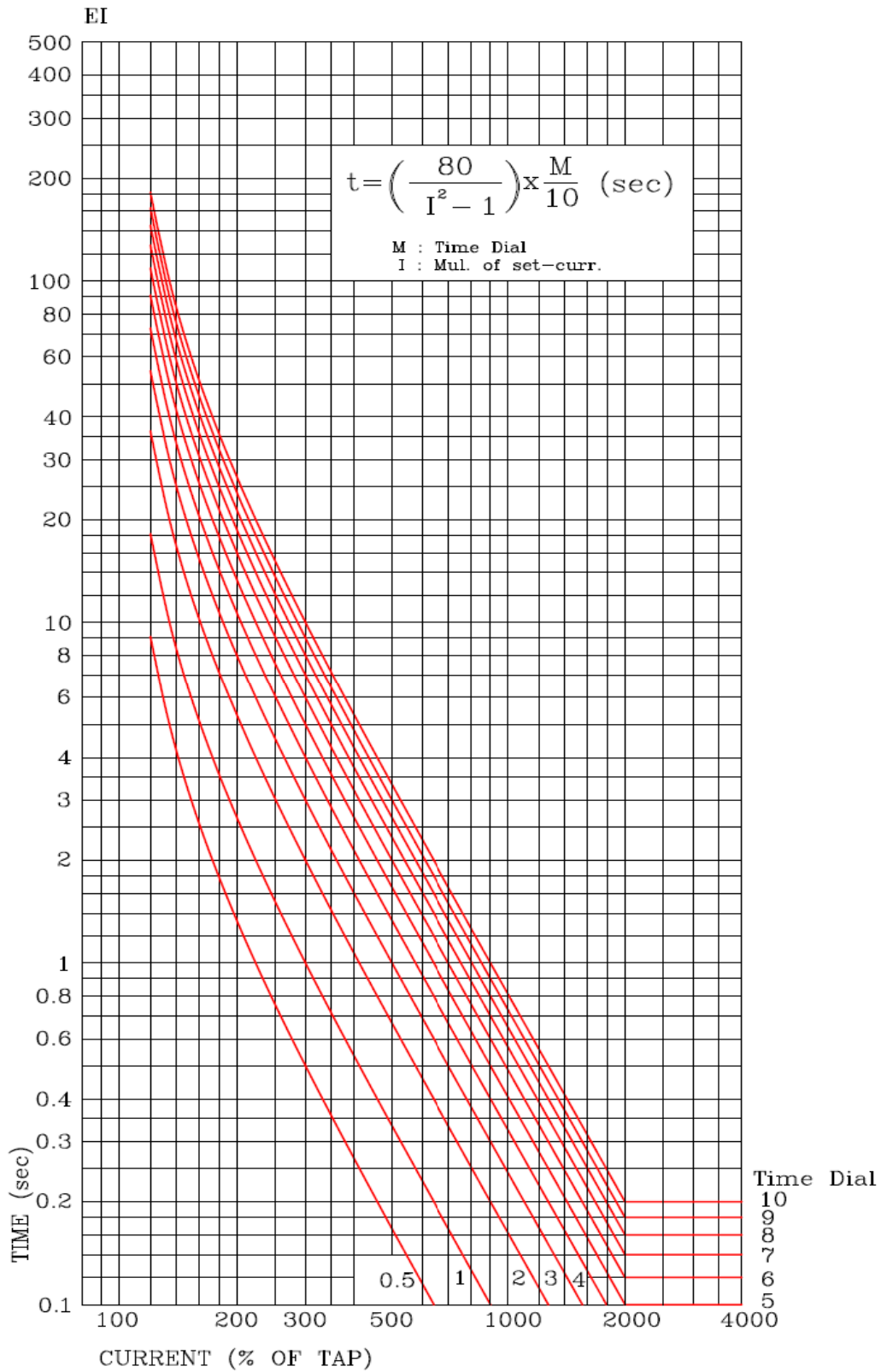

<Appended 1.4 Over-Current/Grond Over-Current EI Characteristic Curve>

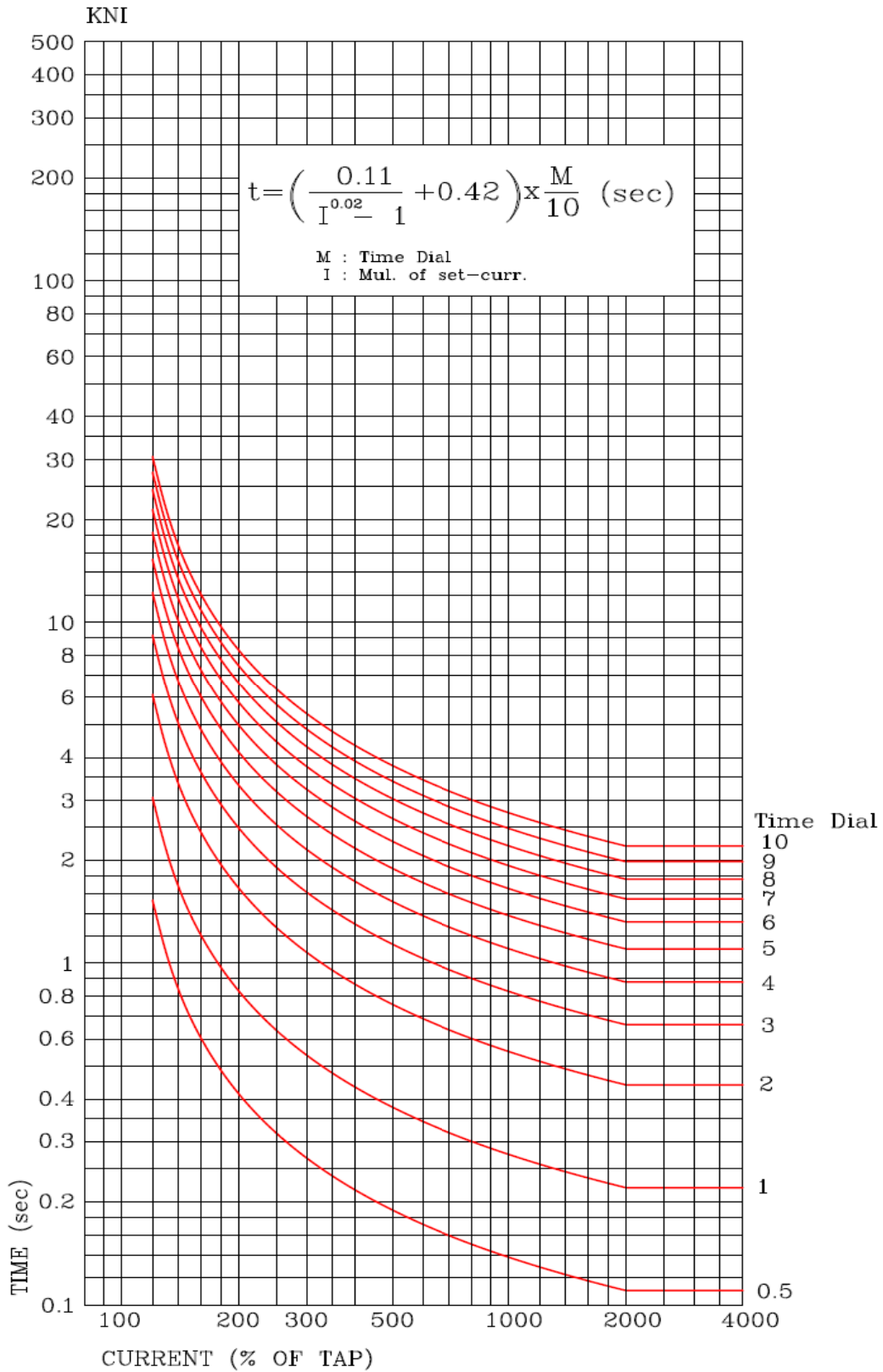

<Appended 1.5 Over-Current/Groud Over-Current KNI Characteristic Curve>

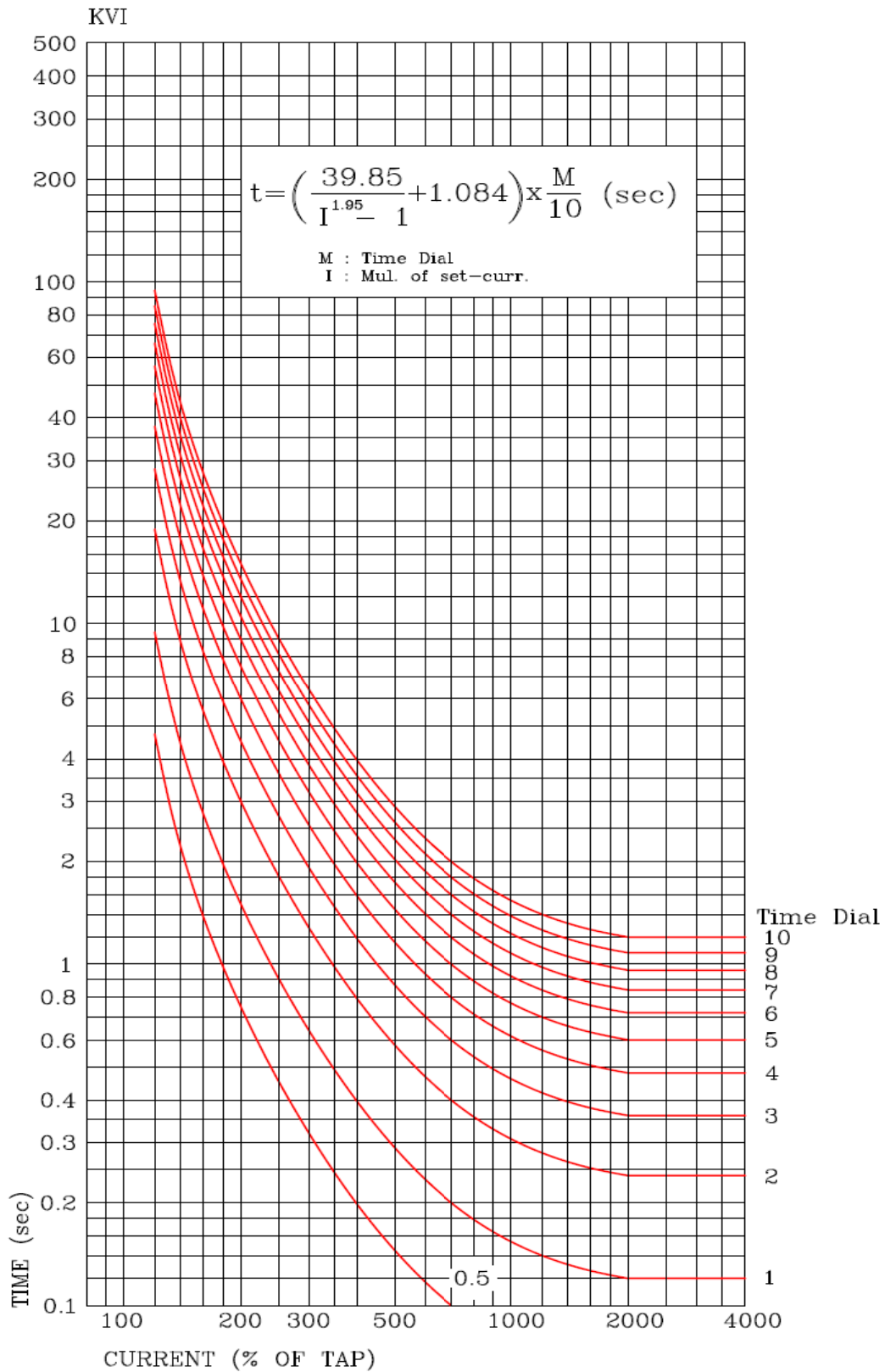

<Appended 1.6 Over-Current/Ground Over-Current KVI Characteristic Curve>

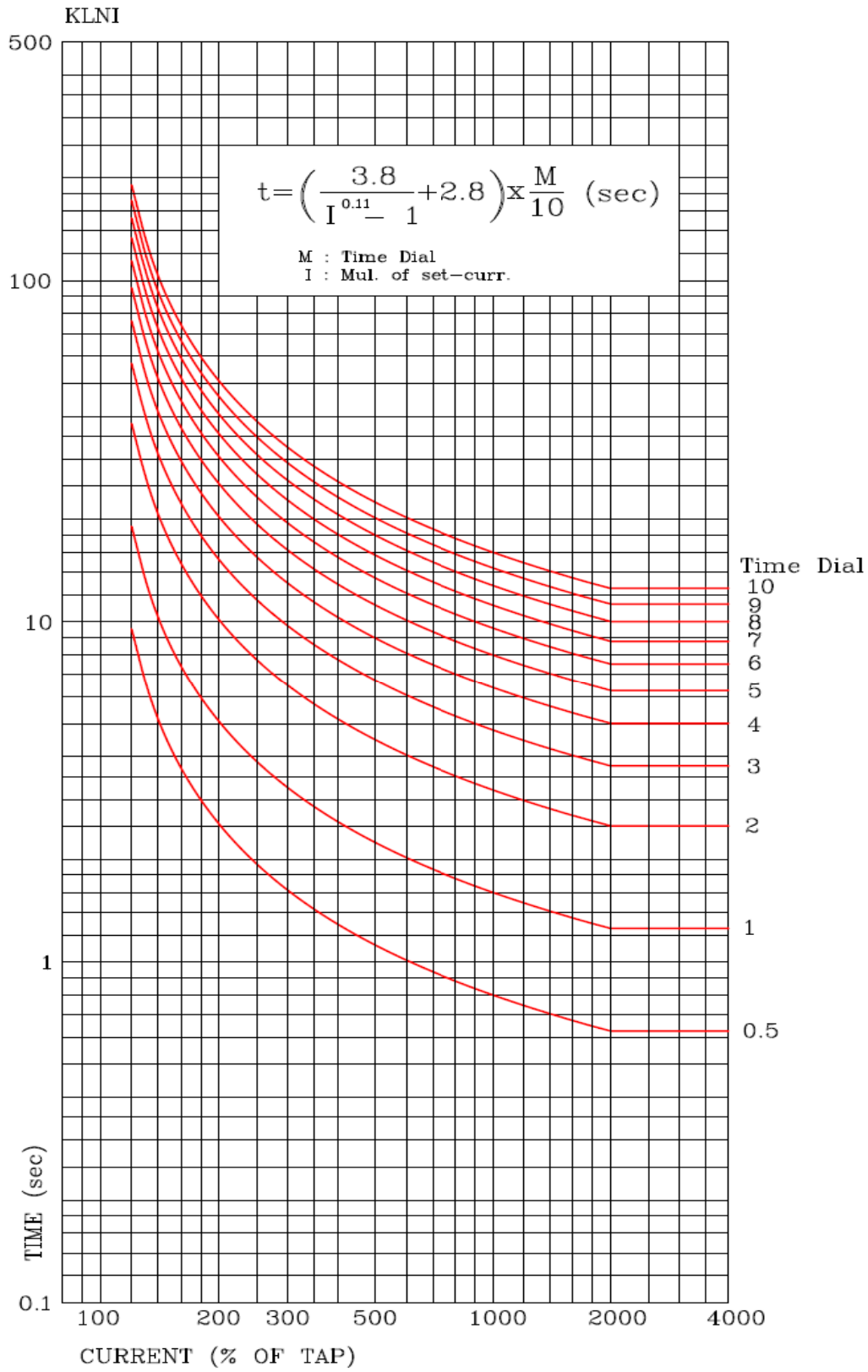

<Appended 1.7 Over-Current/Grond Over-Current KLNI Characteristic Curve>

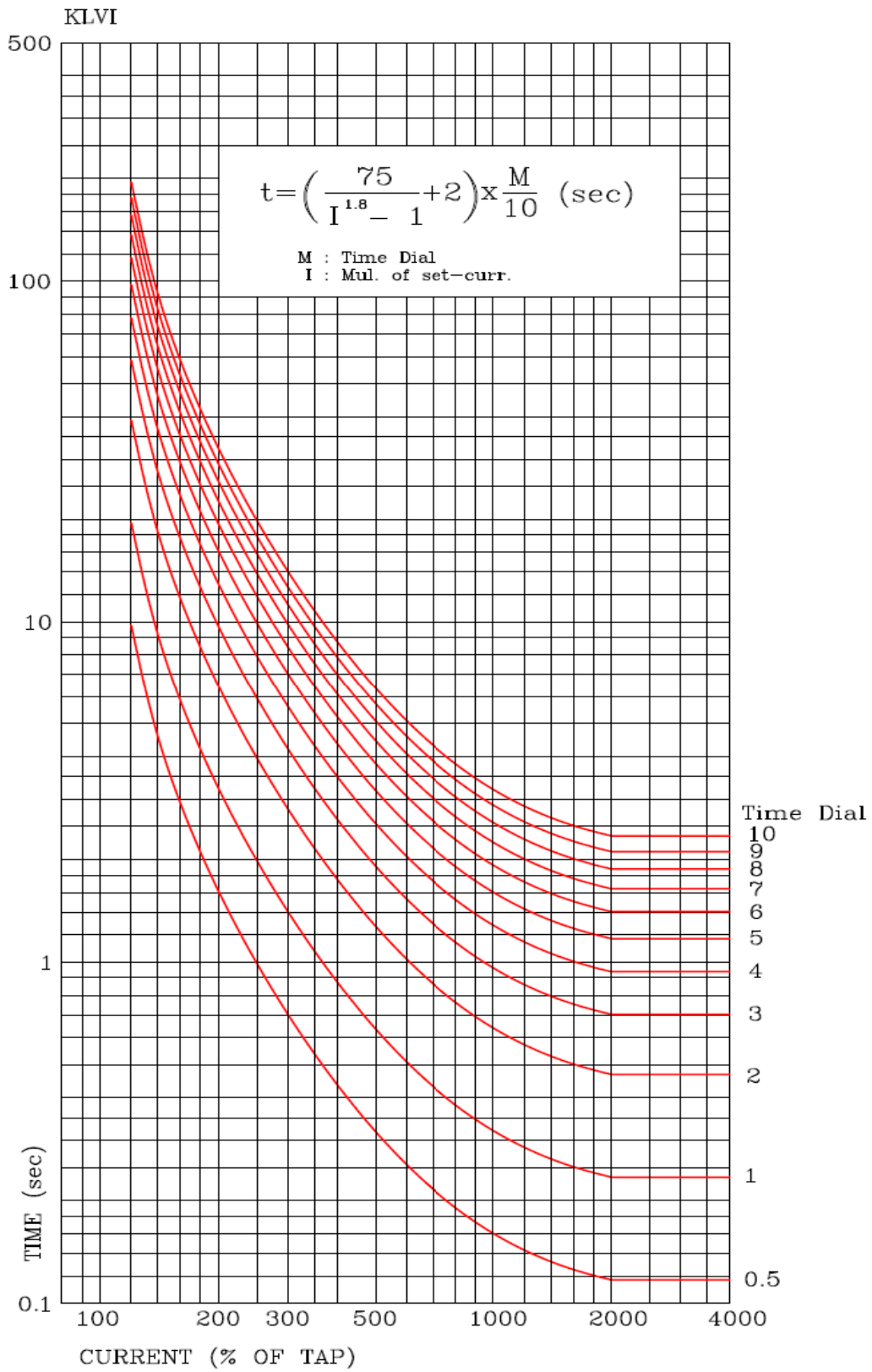

<Appended 1.8 Over-Current/Ground Over-Current KLVI Characteristic Curve>

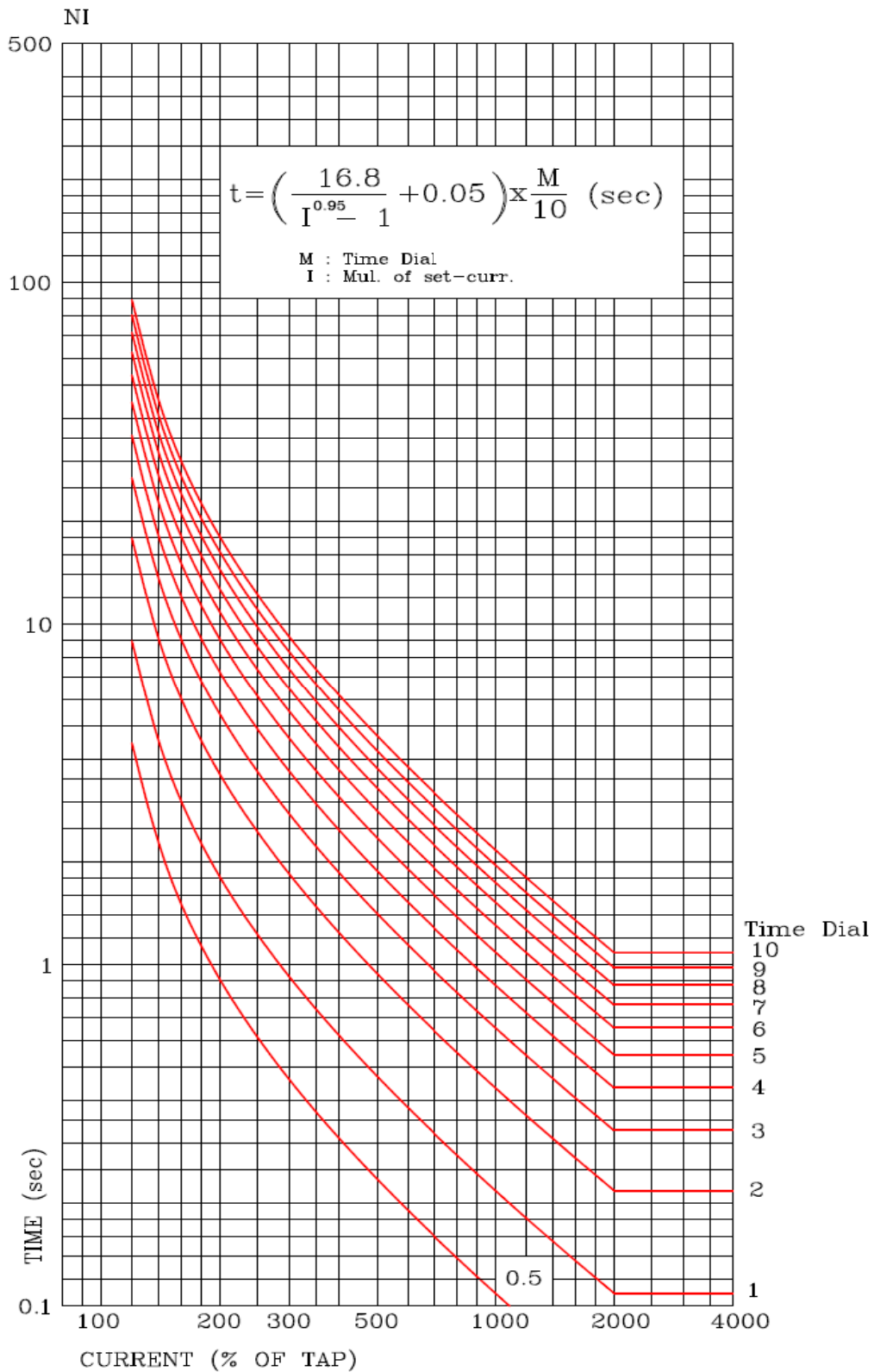

<Appended 1.9 Select Ground Over-Current Inverse Time Characteristic Curve>

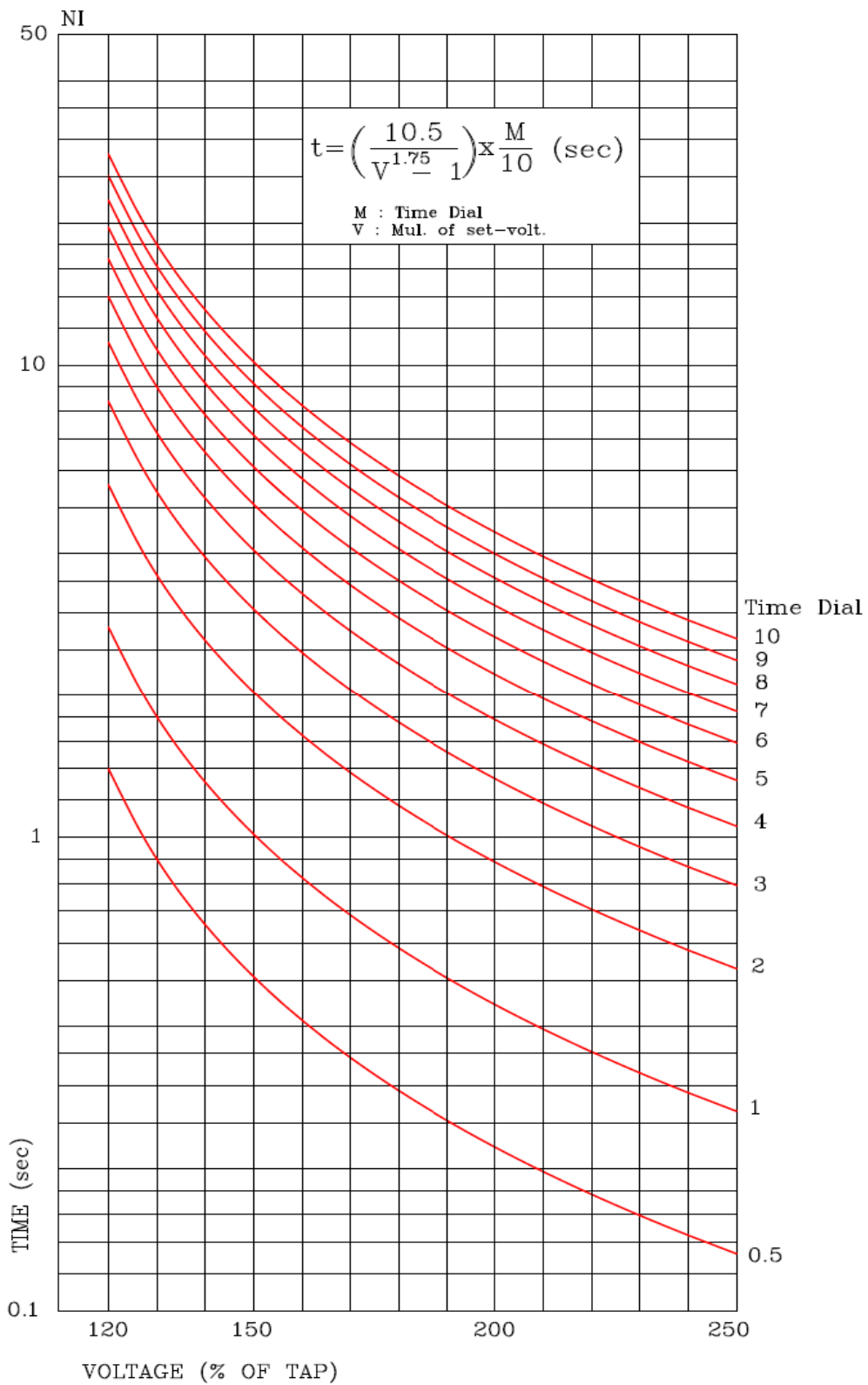

<Appende 1.10 Over-Voltage Inverse Time Characteristic Curve>

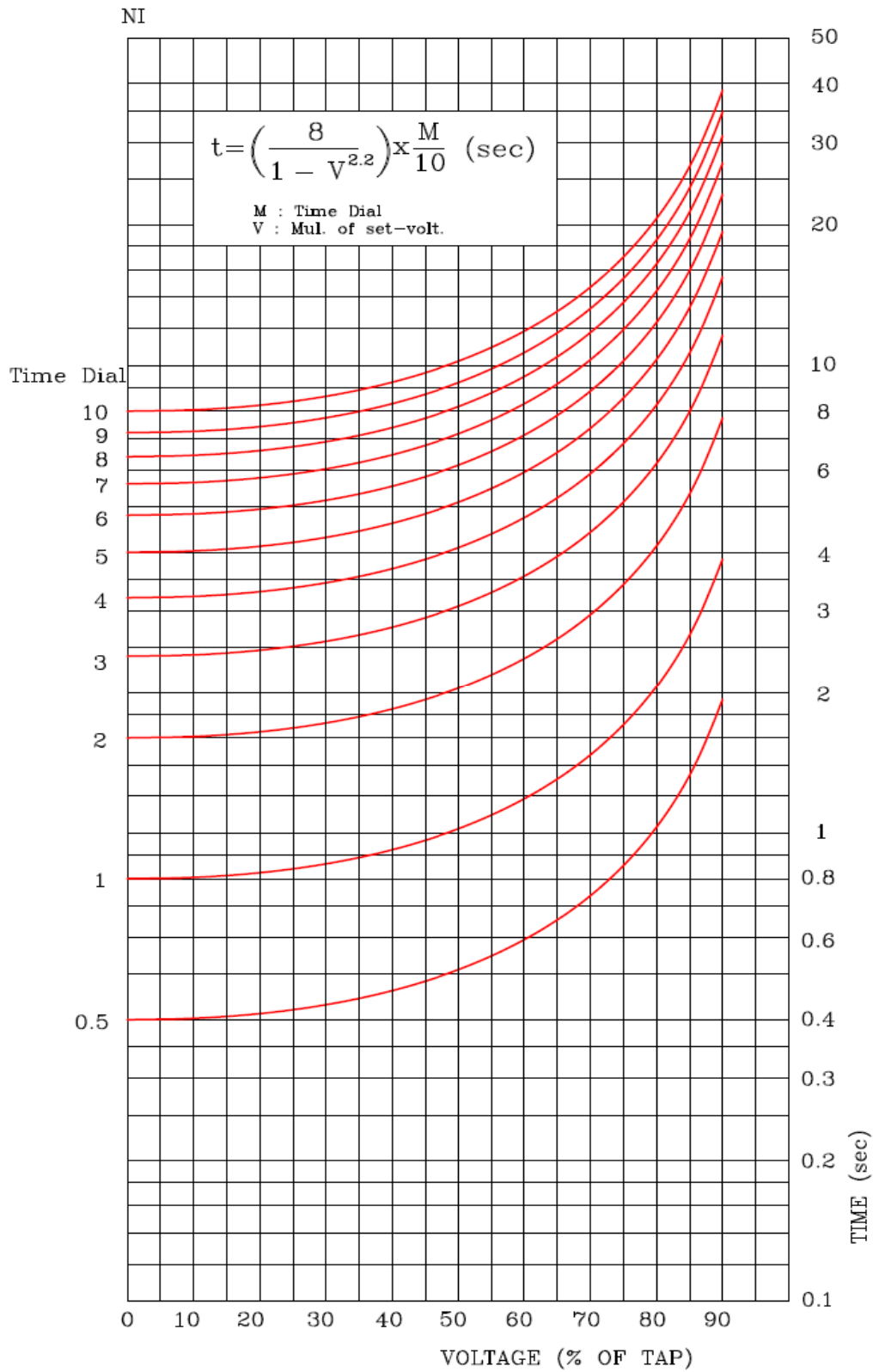

<Appended 1.11 Under-Voltage Reverse Inverse Time Characteristic Curve>

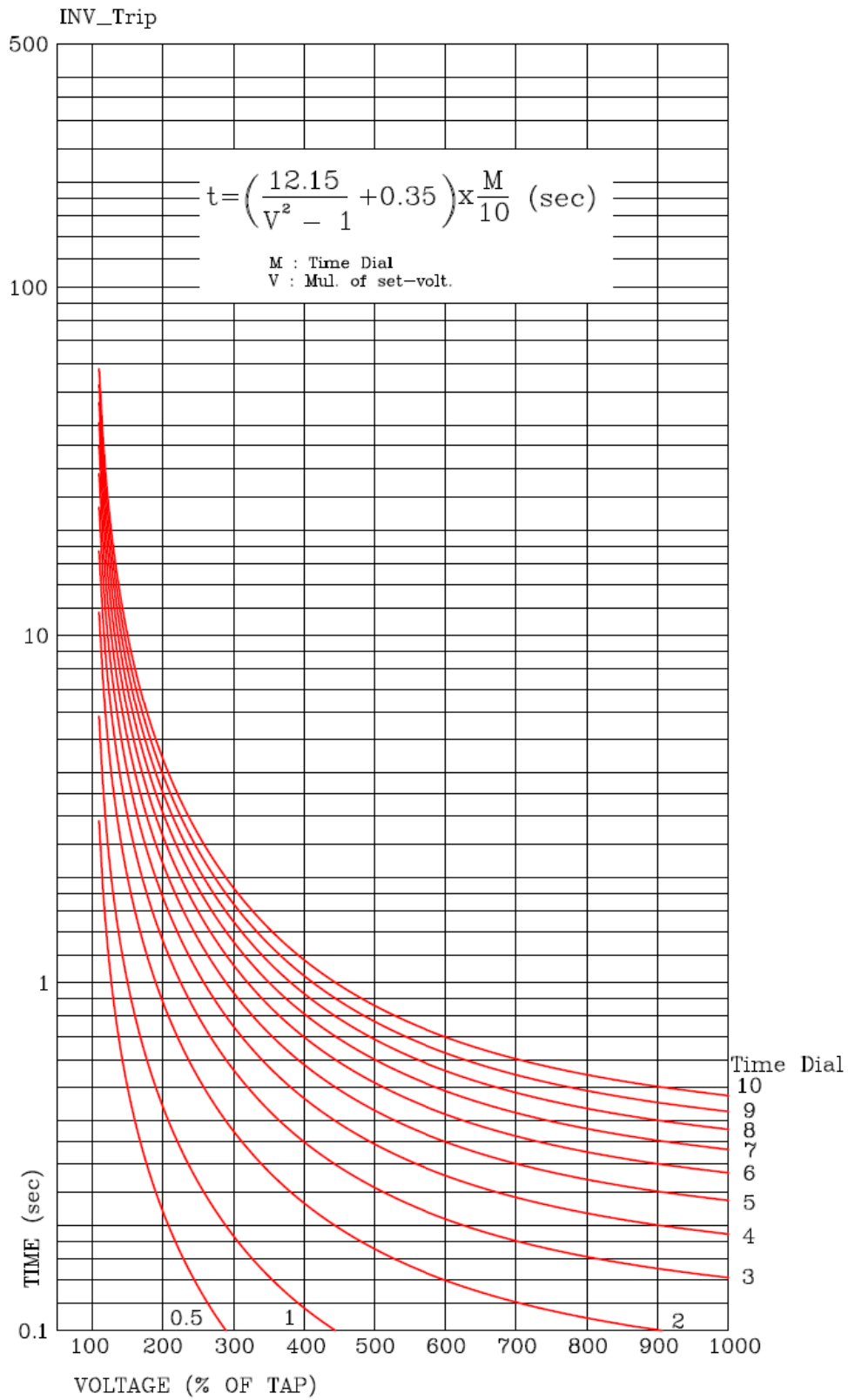

<Appended 1.12 Ground Over-Voltage For Trip Inverse Time Characteristic Curve>

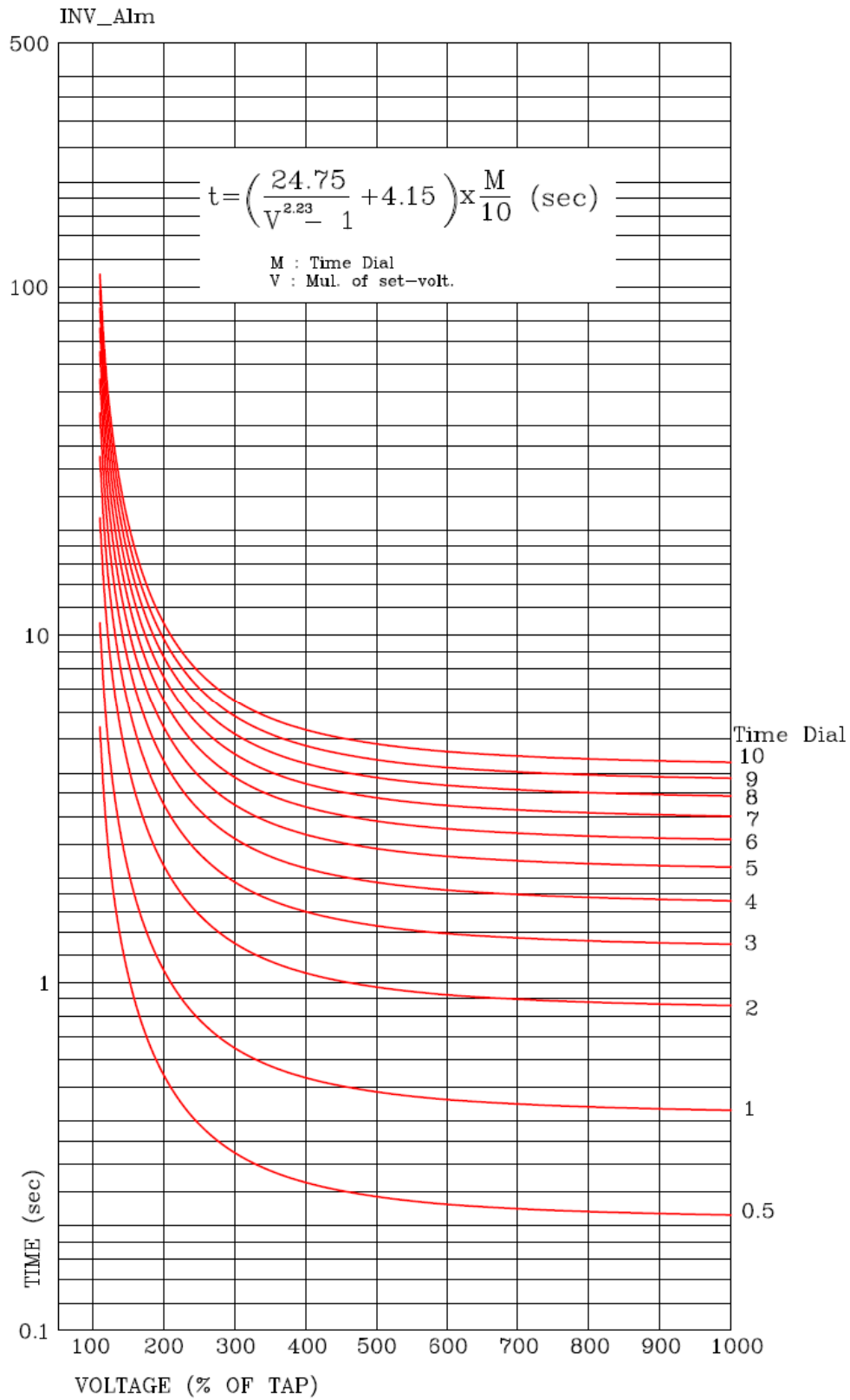

<Appended 1.13 Ground Over-Voltage For ALARM Inverse Characteristic Curve>

Appendix A. Product Shipping Setting Value

I n I t I a l D I s p l a y	Setting Mode	1. Protection	1.TOCR	1.Function	ENABLE
				2.Curve	KNI
				3.PickUp	5 [A]
				4.T_Dial	10
				5.DT_Time	-
			2.IOCR	1.Function	ENABLE
				2.Curve	INST
				3.PickUp	20 [A]
				4.DT_Time	-
			3.TOCGR	1.Functio	ENABLE
				2.Curve	KVI
				3.Direction	DISABLE
				4.In_PKP	0.5 [A]
				5.T_Dial	10
				6.DT_Time	-
				7.Vn_PKP	15 [V]
				8.MTA	-60 [°]
			4.IOCGR	1.Function	ENABLE
				2.Curve	INST
				3.Direction	DISABLE
				4.In_PKP	10 [A]
				5.DT_Time	-
				6.Vn_PKP	15 [V]
				7.MTA	-60 [°]
			5.SGR	1.Function	ENABLE
2.Curve	DT				
3.Direction	FORWARD				
4.Is_PKP	1 [mA]				
5.T_Dial	1				
6.DT_Time	1.00 [sec]				
7.Vn_PKP	30 [V]				
8.MTA	45 [°]				
6.OVR	1.Function	ENABLE			
	2.Curve	NI			
	3.Pickup	125 [V]			
	4.T_Dial	1			
	5.DT_Time	-			

I n I t I a l D I s p l a y	Setting Mode	1. Protection	7.UVR	1.Function	ENABLE
				2.Curve	NI
				3.Pickup	90 [V]
				4.T_Dial	1
				5.DT_Time	-
				6.OP_MODE	INDUCTION
			8.TOVGR	1.Function	ENABLE
				2.Curve	TRIP_NI
				3.Pickup	35 [V]
				4.T_Dial	10
				5.DT_Time	-
			9.IOVGR	1.Function	DISABLE
				2.Curve	NI
				3.Pickup	125 [V]
	4.T_Dial	1			
	5.DT_Time	-			
	10.NSOVR	1.Function	ENABLE		
		2.Pickup	30 [V]		
		3.DT_Time	0.10 [sec]		
	2. SYSTEM	1.Power System	1.FREQ	60Hz	
			2.PT_CON	Wye	
			3.P_PT_SEC	110.0 V	
			4.P_PT_RAT	1.0	
			5.G_PT_SEC	190.0 V	
			6.G_PT_RAT	1.0	
			7.P_CT_RAT	5	
			8.G_CT_RAT	5	
		2.CB Control	1.Function	ENABLE	
2.Key Control			ENABLE		
3.CB OPEN Time			0.5 Sec		
4.CB CLOSE Time			1.0 Sec		
5.CB Input			52a+52b		

I n I t I a l D I s p l a y	Setting Mode	2. SYSTEM	3.T/S Output	T/S 1	1.CON	CB OPEN
					2.RST	SELF
					3.DLY	0
				T/S 2	1.CON	CB CLOSE
					2.RST	SELF
					3.DLY	0
				T/S 3	1.CON	ALL PROT
					2.RST	SELF
					3.DLY	0
				T/S 4	1.CON	OCR
					2.RST	SELF
					3.DLY	0
				T/S 5	1.CON	OCGR+SGR
					2.RST	SELF
					3.DLY	0
				T/S 6	1.CON	OVR
					2.RST	SELF
					3.DLY	0
				T/S 7	1.CON	UVR
					2.RST	SELF
					3.DLY	0
				T/S 8	1.CON	OVGR
					2.RST	SELF
					3.DLY	0
				T/S 9	1.CON	NSOVR
					2.RST	SELF
					3.DLY	0
		T/S 10		1.CON	SYS ERR	
				2.RST	SELF	
				3.DLY	0	
4.Waveform Record	1.T_POS		50%			
	2.T_SRC		OP			
	3.In/Is		In			
5.Communi- cation	1.Protocol		Modbus			
	2.SLAVE_ADDR		1			
	3.BPS		19200			
6.Password		0000				
3.Record Clear	4.Set CB OPEN CNT		0			

Appendix B. External Connection Diagram by Product Shipping Setting Value

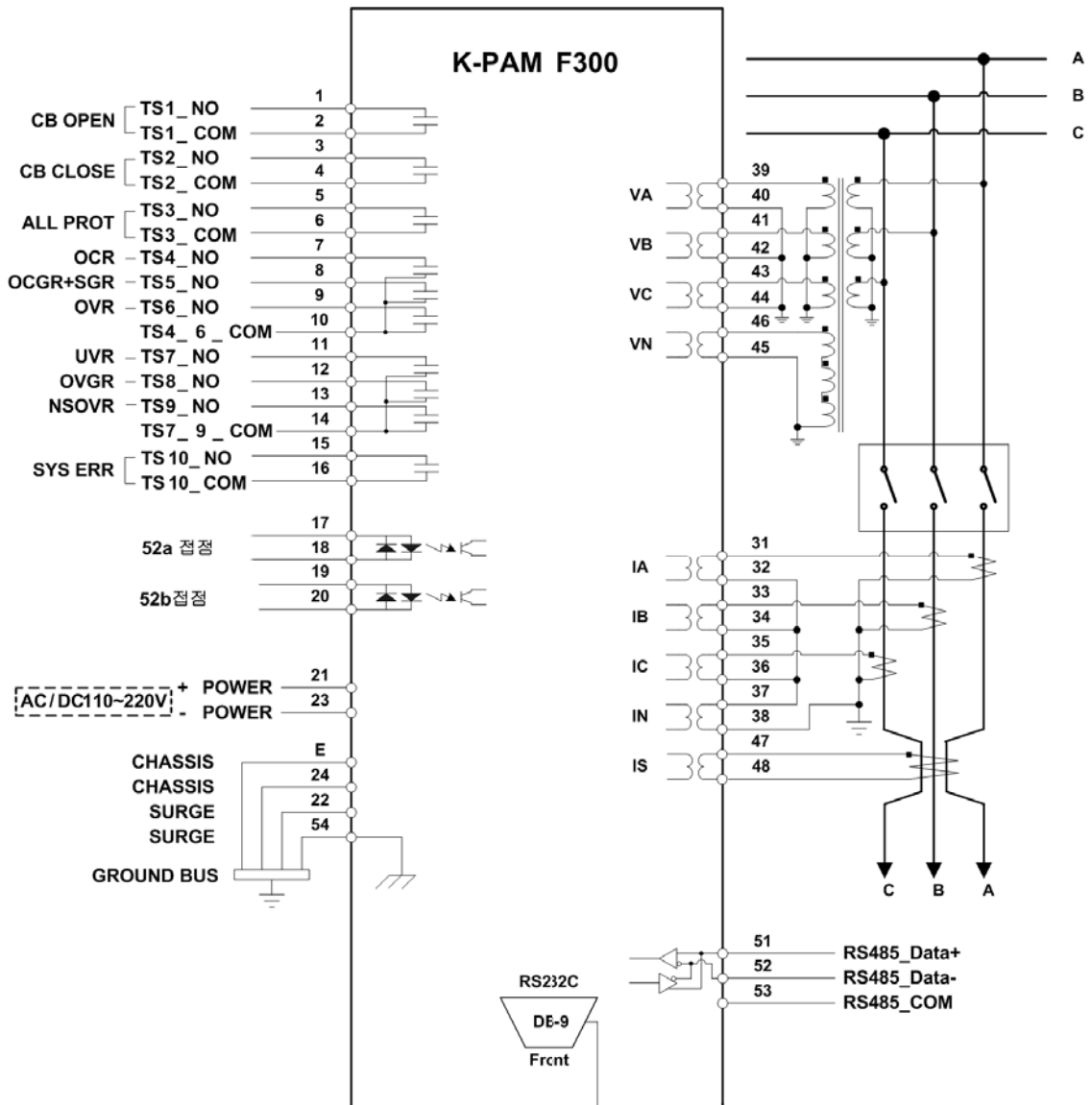

<NOTICE>

1. The above wiring diagram is setting according to product shipping value, therefore you can change yourself.
2. SYS_ERR contact is status when there is not a fault in the relay in auxiliary power input status.

KyongBo Co., Ltd

(Sales department)

Address: 284-5, seongsu 2-ga 3-dong, Seongdong-gu, Seoul, Korea.
Call: 02) 465-1133 (Ext. 100)
Fax: 02) 465-1333

(Laboratory)

Address: 284-5, seongsu 2-ga 3-dong, Seongdong-gu, Seoul, Korea.
Call: 02) 465-1133 (Ext. 126)
Fax: 02) 465-1333

(A/S department)

Address: 284-5, seongsu 2-ga 3-dong, Seongdong-gu, Seoul, Korea.
Call: 02) 465-1138 (Ext. 129)
Fax: 02) 465-1333

Homepage: <http://www.kyongbo.co.kr/>